

PRODUCT GUIDE

2024/25

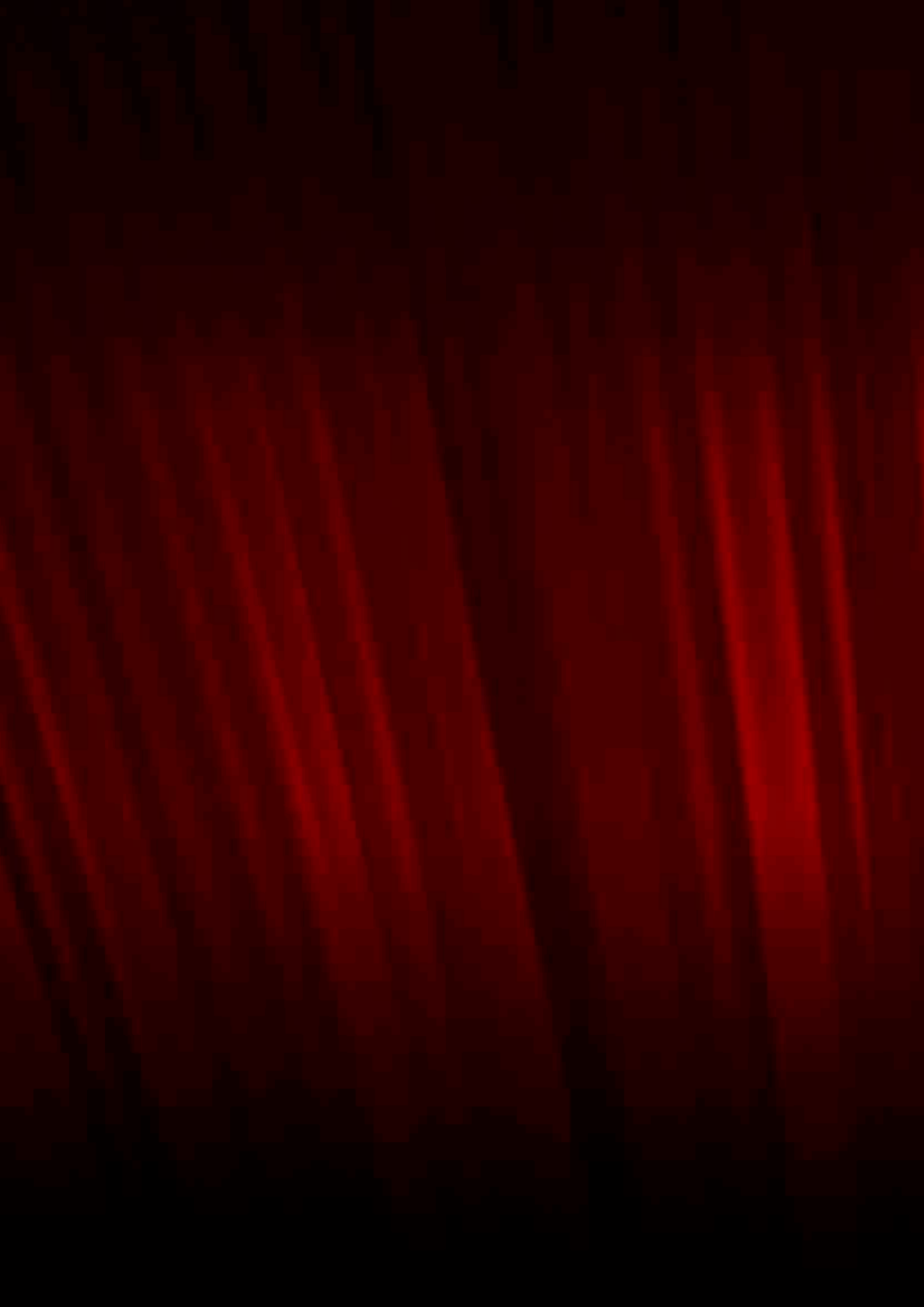

TURNTABLES • HIFI ELECTRONICS • LOUDSPEAKERS



About Pro-Ject
4-11

Product Overview
12-19

Turntables
20-77

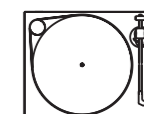

HiFi Electronics
78-105

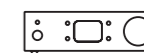

Speakers
106-115



Accessories
116-157





1991 THE START

with the launch of the first Pro-Ject turntable, named Pro-Ject 1, CEO Heinz Lichtenegger founded the brand.



1997 DEBUT

with the idea of turning a HiFi product into a lifestyle product, the Debut turntable was born and was sold almost 1 Million times until today.



2000 NEW FACTORIES

in order to produce the electronics, new partnerships were formed in Czech Republic and Slovakia.



Since 2015 ARTIST COLLECTION

the turntable collection in cooperation with famous musicians started with Austrian artist Parov Stelar. Later: The Beatles, Rolling Stones, Vienna Philharmonics and now Metallica.



2021 30th YEAR ANNIVERSARY

Pro-Ject celebrates this year with the Debut PRO.



CEO and Founder
Heinz Lichtenegger

2024 PRO-JECT TODAY

has more than 5.000 dealers in 80 countries, is world leader for HiFi turntables and Micro High End components, has won over 100 international Awards, among several EISA Awards and the Red Dot Design Award and has over 500 employees in four factories.

1993 PARTNERSHIP

after the collapse of the iron curtain, Heinz Lichtenegger formed a partnership with a former Tesla factory in Czech Republic that is, until today, producing for Pro-Ject Audio Systems.

1994 Pro-Ject 6

first High End turntable.

1998 BOX-DESIGN

Pro-Ject started to produce their own HiFi Electronics.



2007 DIGITAL ENTRY

Pro-Ject introduces first digital products: Pre Box, Amp Box, and DAC Box.



2017 HEADQUARTERS

opening of the new headquarters in Lower Austria, including an office, a logistics center, administration, Research & Development.

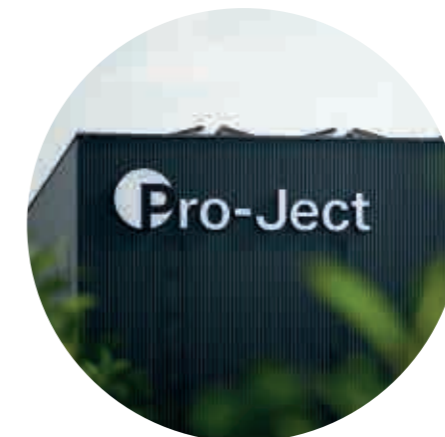

2023 EVO TONEARMS

Pro-Ject releases 24 different High precision tonearms hand-made in Europe

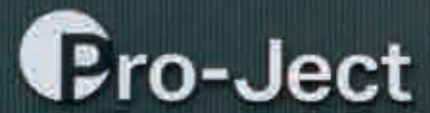

The Pro-Ject logo is displayed in white on a dark green, vertically-ribbed wall. It consists of a circular icon with a stylized 'P' and the brand name 'Pro-Ject' in a sans-serif font.

Grand slam! On and off the court.
Our headquarters is located 35
kilometers North of Vienna in the
beautiful Weinviertel region...

CEO
Heinz Lichtenegger



Live music and HiFi Stereo

Live musical events at our headquarters are always an impressive experience for those able to attend. We support local musicians and encourage people to listen to music live. There is no better reference than live music to evaluate a high-quality HiFi playback system.



"Our aim is to get as many people
as possible into the wonderful
world of HiFi Stereo!"

Pro-Ject Audio Systems at home in Europe

We are an Austrian company that has been supplying the world with turntables since 1991 and Hi-Fi components since 2000.

Everything as local as possible

- Production is carried out in the heart of Europe
- Factories in the Czech Republic, Slovakia, Austria and Germany

97% are sourced from the immediate vicinity of the factories

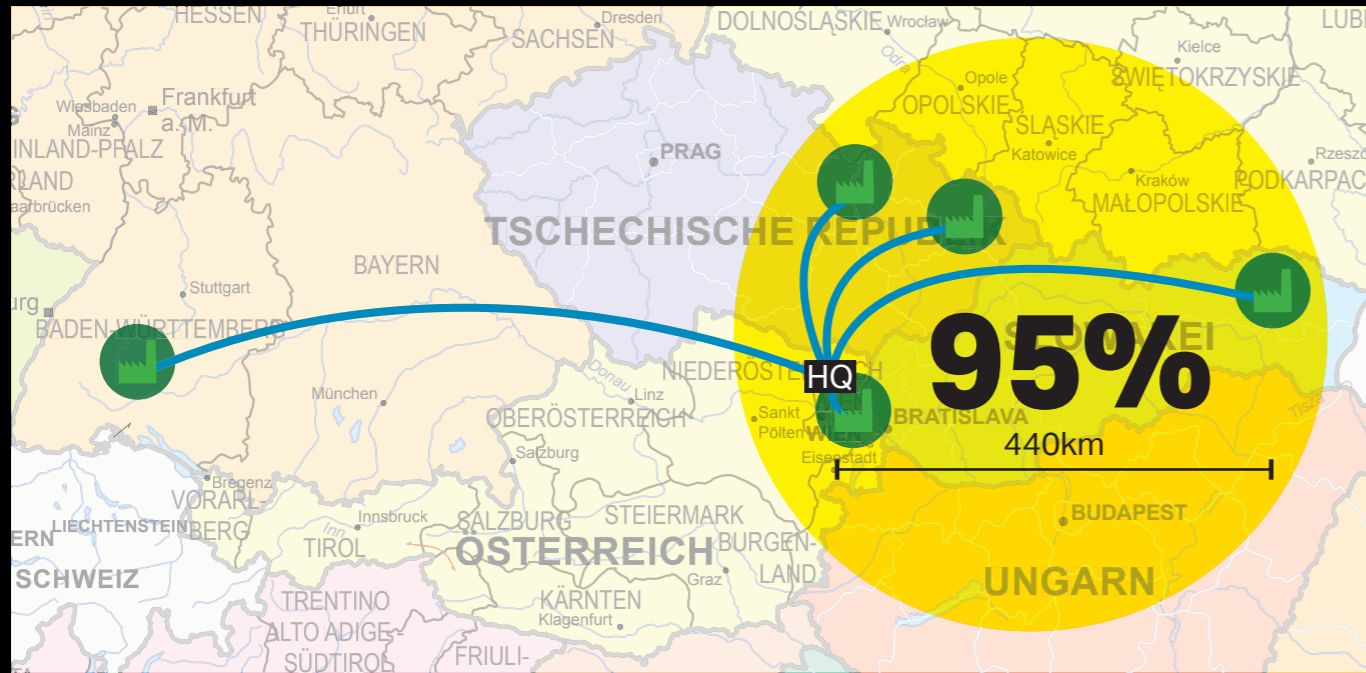

Factory Perimeter of raw material procurement

Products designed for generations

- Anti-Throwaway-Culture
- Spare parts availability for at least 25 years
- High quality materials
- Stable in value for many years
- Focus on sound quality instead of short lived features most people don't use



Scan and receive more information about our Sustainability concept.



Turntables Made in EU

With cutting edge technologies and machines, we are able to create visually pleasing products without losing the eye for the finest details. In the Czech Republic, we produce all our turntables from scratch, by hand and in house.



Why True Balanced Connection for Phono?

All Pro-Ject turntables with outlets are balanced by nature. The industry standard is usually an unbalanced RCA connection as this connection type is cheaper and already widely adopted compared to a really balanced one.

True Balanced Connections can access details embedded in the valuable grooves of your records that you've never heard before.

Liberate your HiFi stereo system from unwanted noise and interference. Get closer to the music you love and take your musical experience to the next level.



Phono Signal ~ 1 mV
 CD/Line Signal ~ 1000 mV
 1000x smaller voltage

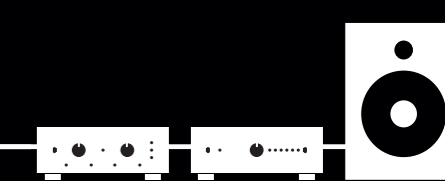

- Interference-free signal
- Increased dynamics
- Lower noise level

Present day problems

Nowadays, many electromagnetic fields interfere with turntables. The causes are wireless networks and numerous electronic devices in the modern home. The RCA cable between your turntable and your amplifier is prone to picking up noise on the way. This so-called "electrosmog" can interfere with the tiny phono signal and add noise to your music.

The Solution

Balanced audio connections are standard among professional musicians, recording studios, and live concerts. It is essential to have a stable & interference-free connection as these signals, especially microphone signals, will be highly amplified. The same applies to the connection from your turntable to the phono pre-amplifier. The significant advantage of a balanced connection is its ability to remove picked up noise and interferences.

True Balanced Ready

To use the **True Balanced Connection**, your turntable needs to be equipped with a Moving Coil (MC) cartridge.

True Balanced Ready turntables are capable of being wired for balanced signals, but are supplied as standard with a Moving Magnet (MM) cartridge.

What do I need for a balanced connection?

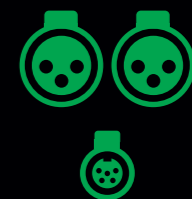

To XLR or Mini XLR Balanced input

Turntables

24

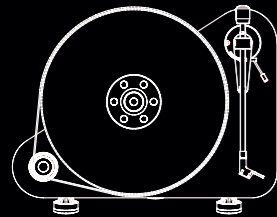

Vertical Line

VT-E
VT-E BT

26

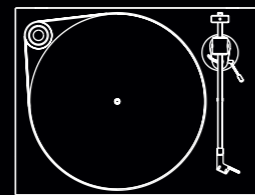

Primary Line

Primary E
Primary E Phono

28

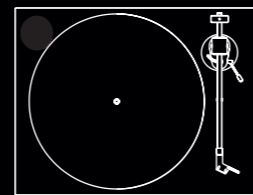

E Line

E1
E1 Phono
E1 BT

30

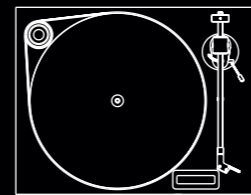

Juke Box Line

Juke Box E1
Juke Box E1 - Stereo Set
Juke Box S2
Juke Box S2 - Stereo Set

32

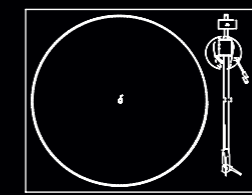

T Line

T1 EVO
T1 EVO Phono
T1 EVO BT
T2
T2 Super Phono
T2 W

36

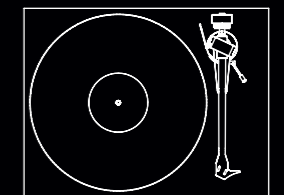

Debut Line

Colourful Audio System
Debut PRO S
Debut PRO B
Debut PRO B White
Debut EVO 2

46

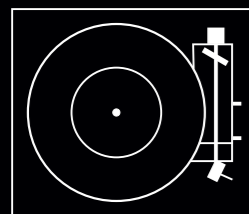

Automat

A1
A2

50

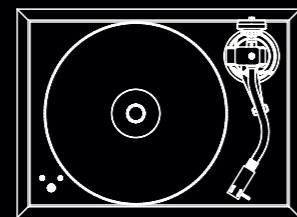

The Classic

The Classic Reference

52

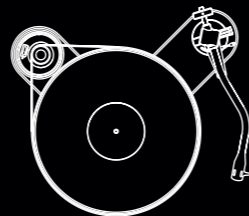

RPM Line

RPM 1 Carbon
RPM 3 Carbon
RPM 5 Carbon
RPM 9 Carbon
RPM 10 Carbon

56

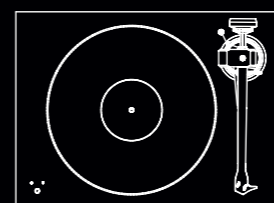

X Line

X1 B
X2 B
XA B
6 Perspex Balanced
X8
Xtension 9 Evolution
Xtension 10 Evolution
Xtension 12 Evolution

72

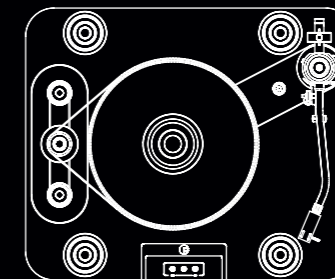

Signature Line

Signature 10
Signature 12.2

74

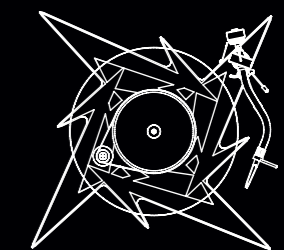

Artist Collection

Pink Floyd
Metallica
The Beatles
George Harrison
Ringo Starr
Rolling Stones
Parov Stelar
Hard Rock
Hans Theessink
DelaDap

HiFi Electronics

80



E Line

Sources

- BT Box E HD
- DAC Box E
- CD Box E

Phono

- Optical Box E Phono
- Phono Box E
- Phono Box E BT5
- Record Box E

82



C Line

- Phono Box MM
- Phono Box

84

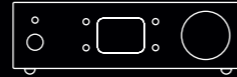

S Line

Amplifier

- Head Box S2
- Head Box S2 Digital
- Pre Box S2 Analogue
- Amp Box S3
- Stereo Box S3 BT
- MaiA S3

Phono

- Phono Box S2
- Phono Box S2 Ultra
- Phono Box S3 B
- Tube Box S2
- Vinyl NRS Box S3
- Power Box S3 Phono

Sources

- Tuner Box S3 DAB+
- CD Box S3
- DAC Box S2+
- Pre Box S2 Digital Edition 23
- BT Box S2 HD
- Stream Box S2 Ultra
- Stream Box S2

Step Up Transformer

- MC Step Up Box S3

Power

- Accu Box S2

92

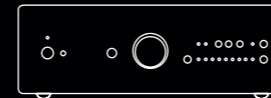

DS Line

Amplifier

- Pre Box DS2 analogue
- Amp Box DS2
- Stereo Box DS3
- MaiA DS3

Sources

- CD Box DS3
- CD Box DS2 T

Phono

- Phono Box DS3 B
- Phono Box DS2
- Tube Box DS3 B

Step Up Transformer

- MC Step Up Box DS3

Power

- Power Box DS3 Sources
- Power Box DS2 Amp

100

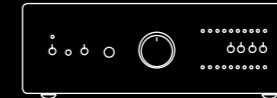

RS Line

Amplifier

- Amp Box RS

Sources

- CD Box RS2 T
- Pre Box RS2 Digital
- DAC Box RS2

Phono

- Phono Box RS2
- Phono Box RS

Power

- Power Box RS Amp
- Power Box RS3 Amp
- Power Box RS2 Phono
- Power Box RS2 Sources
- Power Box RS Uni TT

Remote Control

- Control it RS

Speakers

106

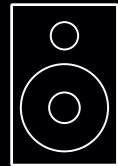

E Line

- Speaker Box 3E
- Speaker Box 3E Carbon
- Speaker Box 5
- Speaker Box 10
- Sub Box 50

112



S Line

- Speaker Box 5 S2
- Speaker Box 10 S2

114



DS Line

- Speaker Box 5 DS2
- Speaker Box 10 DS2
- Speaker Box 15 DS2

118

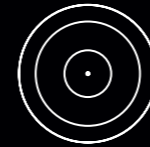

Upgrades

- Acrylic Platters
- Aluminium Sub-Platters
- Ground it
- Record Weights
- Adapt it
- Damp it
- Headshells
- Slip Mats
- Clamp it
- High Power it

122



Care

- Cloth it
- Clean it
- Grease it
- Lube it

123



Adjustments

- Adjust it
- Align it S
- Align it DS3
- Align it PRO
- Level it
- Strobe it
- Mount it
- Measure it E
- Measure it DS
- Measure it S2
- Q up
- VTA it

Accessories

126

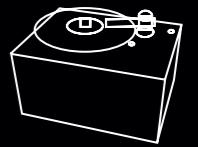

Vinyl Cleaning

- Brush it
- Brush it Premium
- Sweep it E
- Sweep it S2
- VC-S 7" Kit
- Vinyl Cleaner VC-E2
- Vinyl Cleaner VC-S3
- Spin Clean
- Wash it 2
- Accessorie Sets

130



Headphones

- Hear it One
- Hear it Two

131

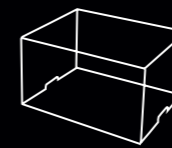

Dustcovers

- Cover it E
- Cover it RPM 1/3 Carbon
- Cover it RPM 5/9
- Cover it 1
- Cover it 2.1
- Dustcover Metallica

132

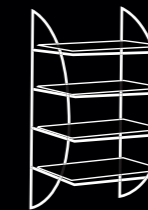

Lifestyle

- Wallmount it Rack 5/4
- Wallmount it
- Tristand

Accessories

134

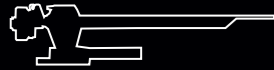

Tonearms

- Tonearm EVO 9 CC Black
- Tonearm EVO 9 CC HG
- Tonearm EVO 10 CC Black
- Tonearm EVO 10 CC HG
- Tonearm EVO 12 CC Black
- Tonearm EVO 12 CC HG

- Tonearm EVO 9 CA Premium Black
- Tonearm EVO 9 CA Premium HG
- Tonearm EVO 10 CA Premium Black
- Tonearm EVO 10 CA Premium HG
- Tonearm EVO 12 CA Premium Black
- Tonearm EVO 12 CA Premium HG

- Tonearm EVO 9 AS Black
- Tonearm EVO 9 AS HG
- Tonearm EVO 10 AS Black
- Tonearm EVO 10 AS HG
- Tonearm EVO 12 AS Black
- Tonearm EVO 12 AS HG

- Tonearm EVO 9 AS Premium Black
- Tonearm EVO 9 AS Premium HG
- Tonearm EVO 10 AS Premium Black
- Tonearm EVO 10 AS Premium HG
- Tonearm EVO 12 AS Premium Black
- Tonearm EVO 12 AS Premium HG

Signature Tonearms 9, 10, 12

142



Cartridges

MC

- Pick it MC1
- Pick it MC2
- Pick it MC3
- Pick it MC9

Upgrades

- Lead it C
- Lead it Premium Silver
- Pin it
- Headshell Spacer Carbon

MM

- Pick it PRO Balances
- Pick it PRO
- Pick it S2 MM
- Pick it S2 C
- Pick it 2M Silver
- Pick it 25A
- Pick it Mono
- Pick it MM EVO

146



Cables

New Concept

- Connect it E
- Connect it S
- Connect it DS
- Connect it RS

152



Records & Merch

Selected Vinyl Records

- 7 Ray - Jazzy Zoetrope
- Beethoven - Symphonie 6
- Brauer - Von Haus zu Haus
- DelaDap - ReJazzed
- Gin Ga - Yes/No
- Hans Theessink
- Mahler - Symphony No. 2
- Mistyca Macumba
- Riccardo Muti - Mozart
- Richard Strauss
- Vinyl Essentials

Merchandise

- HiFi Stereo T Shirt
- Lanyard
- Linen Bag
- Polo Shirt
- Scent it Candle
- Scent it Soap



TURNTABLES

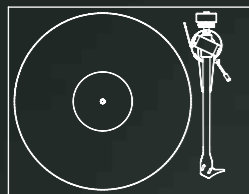

10 reasons for our turntables

1. Performance over features
2. Quality plinths
3. Spindles & bearings
4. Quality platters
5. Quality motors
6. Made in Europe
7. Quality cables
8. Serious tonearms
9. Quality cartridges
10. 25-year spare part guarantee





VT-E



VT-E



Vertical turntable with easiest possible vertical set-up including wall-mount option!

Cartridge Ortofon OM 5E Elliptical stylus	Tonearm 8,6", one-piece alu, saphire bearings	Drive Principle Belt drive on platter	Speed 33/45 RPM Electronic change
Chassis and Platter Veneered particle board	Output Phono out	Included Items Record clamp, felt mat, power supply, Connect it E	Size and Weight 430 x 345 x 245 mm (WxHxD) 2.8 kg (net)

Colour Options    Matt white, black, red: 449 €

VT-E BT



Vertical BT turntable with easiest possible vertical set-up including wall-mount option!

Cartridge Ortofon OM 5 Elliptical stylus	Tonearm 8,6", one-piece alu, saphire bearings	Drive Principle Belt drive on platter	Speed 33/45 RPM Manual change
Chassis and Platter Made from MDF/plywood	Output Line or Phono Bluetooth	Included Items Record clamp, felt mat, power supply, Connect it E	Size and Weight 430 x 345 x 245 mm (WxHxD) 2.8 kg (net)

Colour Options    High-Gloss white, black, red: 599 €

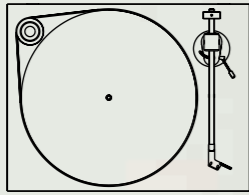

Perfect turntable for vinyl-beginners

The Primary Line offers excellent craftsmanship, high class components and wonderful sound. It is our traditional entry-level range and gives a qualitative high price-performance-ratio.

Primary E



Audiophile plug&play turntable.

Cartridge Ortofon OM Spherical stylus	Tonearm 8,6", aluminium Saphire bearing	Drive Principle Belt-drive with synchronous motor	Speed 33/45 RPM Manual change
Chassis and Platter Made of plywood	Output Phono out Pre-mounted RCA cable	Included Items Dust cover, felt mat, power supply	Size and Weight 420 x 112 x 330 mm (WxHxD) 4.0 kg (net)

Colour Options    Matt white, black, red: 279 €

Primary E Phono



Audiophile plug&play turntables with built in phono stage.

Cartridge Ortofon OM Spherical stylus	Tonearm 8,6", aluminium Saphire bearing	Drive Principle Belt-drive with synchronous motor	Speed 33/45 RPM Manual change
Chassis and Platter Made of plywood	Output Switchable Line/Phono Gold-plated contacts	Included Items Dust cover, felt mat, power supply, Connect it E	Size and Weight 420 x 112 x 330 mm (WxHxD) 4.0 kg (net)

Colour Options    Matt white, black, red: 329 €



E1



E1 BT € 399,-

Special
With BT transmitter for wireless streaming

Output
With switchable phono preamplifier

E1 Phono € 329,-

Output
With switchable phono preamplifier



E1 € 299,-

Output
Phono out:
Pre-mounted RCA cable

Plug & Play Entry Level Turntable

Cartridge AT 3600L Elliptical stylus (MM)	Tonearm 8,6", one-piece aluminium, fast traction	Drive Principle Belt drive on sub-plat- ter aluminium pulley	Speed 33/45 RPM electronic change
Chassis and Platter Plywood chassis, Anti-resonant ABS polymer main platter	Output Depends on model	Included Items Dust cover, felt mat, power supply, Connect it E	Size and Weight 420 x 112 x 330 mm (WxHxD) 3,5 kg (net)

Colour Options    White, Black, Walnut - starting at € 299,-

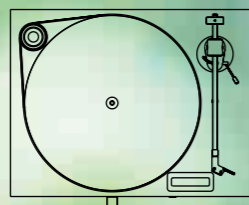

Audiophile "All-in-one Plug & Play" turntable system

The Juke Box Line is the optimum solution with analogue and digital inputs, a power amplifier and true stereo sound built into the chassis of a great sounding turntable.



Prices (Suggested Retail Prices) are only for orientation and can differ depending on local taxes. Prices, technical data and release date without engagement.

Juke Box E1



A turntable, phono stage, Bluetooth receiver, line pre-amplifier and power amplifier in one!

Cartridge Ortofon OM 5E Elliptical stylus	Tonearm 8,6", aluminium Saphire bearing	Drive Principle Belt drive on platter Aluminium pulley	Speed 33/45 RPM Manual change
Chassis MDF and particle board High contrast display Potentiometer on front for controlling the unit	Outputs Speakers, Line out (fixed), Phono out	Included Items Dust Cover, Felt mat, Power supply, IR Remote, Connect it E (RCA cable),	Size and Weight 415 x 118 x 334 mm (WxHxD) 5 kg (net)
Inputs Bluetooth, 1x Line			

Colour Options High-Gloss white, black, red: 599 €

Juke Box E1 - Stereo Set



A complete set including a turntable, speakers, and cables.

Juke Box E A turntable, phono stage, Bluetooth receiver, line pre-amplifier and power amplifier in one!	Speaker Box 5 Audiophile 2-way monitor speakers using bass reflex system. More infos on page 104.	Damp it Damping feet that effectively prevent transmission of unwanted vibrations.	Cable Set Speaker cable: Low distortion level, neutral sound
---	--	--	---

Colour Options High-Gloss white, black, red: 799 €

Juke Box S2



A premium turntable, phono stage, Bluetooth receiver, line pre-amplifier and power amplifier in one!

Cartridge Ortofon Pick it 25A Elliptical stylus	Tonearm 8,6", aluminium Saphire bearing	Drive Principle Belt drive on platter Aluminium pulley	Speed 33/45 RPM Manual change
Chassis and Platter MDF and Acryl High contrast display Potentiometer on front for controlling the unit	Outputs Speakers, Line out (fixed), Phono out	Included Items Dust Cover, Felt mat, Power supply, IR Remote, Connect it E (RCA cable),	Size and Weight 415 x 118 x 334 mm (WxHxD) 5 kg (net)
Inputs Bluetooth, 1x Line			

Colour Options Eucalyptus or Walnut: 899 €

Juke Box S2 - Stereo Set



A complete set including a turntable, speakers, and cables.

Juke Box S2 A turntable, phono stage, Bluetooth receiver, line pre-amplifier and power amplifier in one!	Speaker Box 5 S2 Audiophile 2-way monitor speakers using bass reflex system. More infos on page 105.	Damp it Damping feet that effectively prevent transmission of unwanted vibrations.	Cable Set Speaker cable: Low distortion level, neutral sound
--	---	--	---

Colour Options Eucalyptus or Walnut: 1.499 €

T1 EVO BT

€ 499,-

Special
With BT transmitter for wireless streaming

Output
With switchable phono preamplifier

T1 EVO

€ 399,-

Output
Phono out:
Pre-mounted RCA cable



T1 EVO Phono

€ 449,-

Output
With switchable phono preamplifier



Cartridge
Ortofon OM 10
Elliptical stylus (MM)

Tonearm
8,6", one-piece aluminium, fast traction

Drive Principle
Belt drive on sub-platter aluminium pulley

Speed
Electronic switch
33/45 RPM

Chassis and Platter
Plywood (2.5cm thick)
Blasted-glass platter (8mm thick)

Output
Depands on model

Included Items
Dust cover, felt mat, power supply, Connect it E

Size and Weight
415 x 100 x 335 mm (WxHxD)
3,8 kg (net)

Colour Options



White, Black, Walnut 399 € - 499 €



T2

Cartridge Sumiko Rainier Elliptical stylus (MM)	NEW 9" highly precise and light alu tonearm. Counterweight with nickel finish & spring based anti-skating system	Drive Principle Belt drive on sub-platter aluminium pulley	Speed 33/45 RPM
Chassis and Platter large chassis for high stability & blasted-glass platter (10mm thick)		Included Items Dust cover, felt mat, power supply, Connect it E	Size and Weight 542 x 300 x 412mm (WxHxD) 5,5 kg net

Colour Options White, Black, Walnut 550 €

T2 Super Phono

NEW MM Phono Stage
A truly stunning phono stage to match and give the T2 Super Phono unrivalled longevity and audio performance. The T2 Super Phono debuts a brand new dual-stage split-passive phono preamp design for that reason!

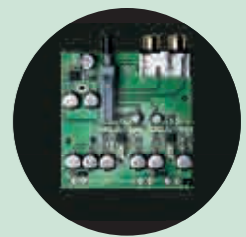
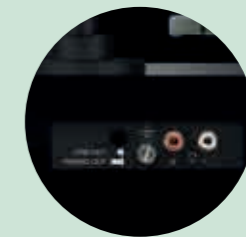

Colour Options White, Black, Walnut 650 €

T2 W

NEW Network Streaming
We have added the latest Wi-Fi technology into the package, including all the latest WLAN standards. The T2 W can either stream in our standard compressed format – enabling maximum compatibility – or in 24bit/48kHz lossless, for selected high-end streamers like our Stream Box S2 Ultra.

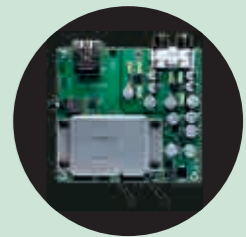

Colour Options White, Black, Walnut: 999 €

DEBUT LINE

Colourful Audio System

This SET contains everything you need for a good stereo sound.
All-In-One True Analog HiFi Stereo System

Colours: Satin Steel Blue, Walnut, Satin White, Satin Black, Satin Golden Yellow, Satin Fir Green € 1.799

Available soon with Debut EVO 2



Speaker Cable 3m

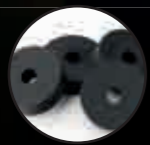

Damp it

Debut Carbon EVO

MaiA S3

Speaker Box 5 S2

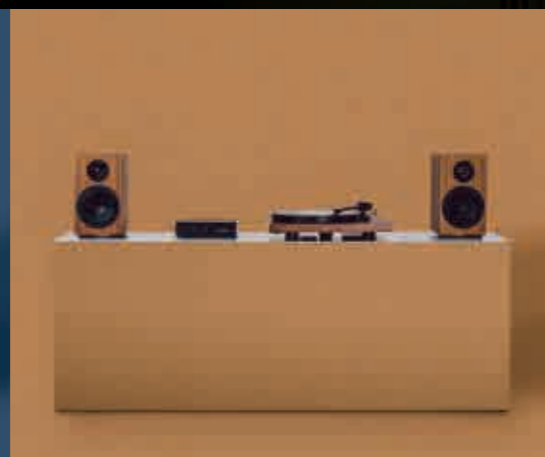



Debut PRO S

Our turntables demand conscious music listening. Debut PRO S takes this philosophy to the extreme. We finished all parts except for the polished spindle in matte black. The manual controls invite the listener to interact with the turntable: turn it on, place the record on the platter, move and lower the tonearm. The musical reward follows the tactile experience. No unnecessary switches, LEDs, or labeling distract from what is essential.

www.project-audio.com/debut-pro-s

Cartridge
Pick it S2 C
Black Edition

Tonearm
Aluminium, S-Shaped
10 inch. Tonearm with
detachable headshell

Drive Principle
Belt drive on
aluminium sub-platter

Speed
33/45/78 RPM
Electronic change

Chassis and Platter
Made of resonance
in-sensitive MDF,
TPE aluminium platter

Output
Phono out
Gold plated sockets

Included Items
Dust cover, felt mat,
Record Puck E black,
power supply,
Connect it E

Size and Weight
462 x 113 x 335 mm
(W x H x D)
8 kg (net)

Black Satin Finish ● 899 €

Debut PRO B

The Debut PRO B is the balanced successor of our award-winning Debut PRO. We've added a mini-XLR socket at the rear to allow a fully balanced setup. The included MM cartridge is balanced right out of the box.



Our 30 years anniversary turntable: www.project-audio.com/debut-pro

Cartridge

Pick it PRO B
Elliptical stylus
US: Sumiko Rainier

Tonearm

8.6" carbon tonearm
sapphire bearings

Drive Principle

Belt drive on
sub-platter

Speed

33/45/78 RPM
Electronic change

Chassis and Platter

Made of resonance
in-sensitive MDF,
TPE aluminium platter

Output

XLR / Phono out

Included Items

Dust cover, felt mat,
power supply,
Connect it E

Size and Weight

415 x 95 x 330 mm
(WxHxD)
5,6 kg (net)

Black Satin Finish ● 899 €



Debut PRO B WHITE

A limited version of Debut PRO
completed in a satin white finish...

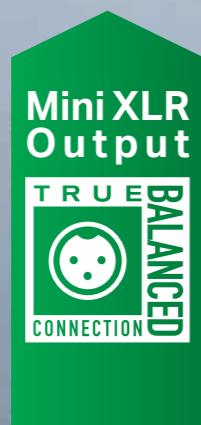







Cartridge 2M White Elliptical stylus	Tonearm 8.6" aluminium tonearm	Drive Principle Belt drive on sub-platter	Speed 33/45/78 RPM Electronic change
Chassis and Platter Made of resonance in-sensitive MDF, TPE aluminium platter	Output XLR / Phono out	Included Items Dust cover, felt mat, power supply, Connect it E	Size and Weight 415 x 95 x 330 mm (WxHxD) 5,6 kg (net)

White Satin Finish ● 899 €

New

Debut EVO 2

Cartridge Pick it MM EVO	Tonearm 8.6" carbon tonearm saphire bearings	Drive Principle Belt drive on sub-platter	Speed 33/45 RPM Electronic change
Chassis and Platter Made of resonance in-sensitive MDF, TPE damped aluminium platter	Output Phono out Gold plated sockets	Included Items Dust cover, felt mat, power supply, Connect it E	Size and Weight 415 x 95 x 330 mm (WxHxD) 5,6 kg (net)

Satin Finish       White, Black, Golden Yellow, Steel Blue, Fir Green, Wine Red: 699 €

High Gloss    Red, White, Black: 699 €

Wood  Real-wood walnut : 699 €





A1

The A1 is handmade in Germany by a traditional manufacturer with a wealth of experience in making automatic turntables. Our new A1 is your best companion to comfortably enjoy your favourite records.



A1

Precise mechanics with automated start and stop: www.project-audio.com/a1



<p>Cartridge Ortofon OM 10</p>	<p>Tonearm The A1 features an 8.3" ultra-light-mass aluminium tonearm. Together with the Ortofon OM10, which fits this design principle perfectly, we get extraordinary fast response and detail in terms of transients and microdynamics.</p>	<p>Output Switchable Phono preamp</p>	<p>Speed Electronic speed selector for 33/45 RPM</p>
<p>Chassis and Platter Precision balanced aluminium platter. The chassis avoids hollow spaces wherever possible, with just enough space to precision fit all the inner workings of the A1.</p>	<p>Drive Principle Belt drive on</p>	<p>Included Items Dust cover, felt mat, power supply, Connect it E (RCA cable)</p>	<p>Size and Weight 430 x 130 x 365 mm (WxHxD) 5,6 kg net</p>

Colour Options ● ● Black: 399 € White: 449 €

Prices (Suggested Retail Prices) are only for orientation and can differ depending on local taxes. Prices, technical data and release date without engagement.

A2

Fully automatic sub-chassis turntable: www.project-audio.com/a2

Cartridge
2M Red

Chassis and Platter
Precision balanced aluminium platter. The new heavy MDF main chassis is made and designed in Austria and carefully hand painted in a luxurious 8-layer matt black finish.

Tonearm
Ultra-light-mass 8,3" aluminium tonearm. The headshell is made of carbon fibre reinforced polymer which makes it super stable and rigid, all while keeping the weight at a lowest to work perfectly with the ultra-light-mass tonearm design.

Output
Phono Out

Drive Principle
Belt drive on

Included Items
Dust cover, felt mat, power supply, Connect it E (RCA cable)

Speed
Electronic speed selector for 33/45 RPM

Size and Weight
430 x 150 x 365 mm (WxHxD)
7,3 kg net

Colour Options ● Black: 1.199,00 €



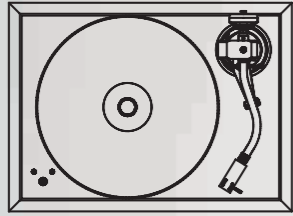

The Classic Reference

The reference in audio reproduction

The Classic Reference



NEW Cartridge
n/c

Chassis and Platter
Metal/MDF sandwich chassis floating on TPE suspension. Precision balanced TPE-damped aluminium platter.

NEW Tonearm
High end 9" S-shape tonearm: EVO 9 AS Premium HG

Drive Principle
Belt drive on diamond cut precision alu sub-platter

NEW Output
Balanced XLR and single-ended outputs on the back

Included Items
Dust cover, Clamp it, Leather it, power supply, Connect it E (RCA cable)

Speed
Electronic speed selector for 33/45/78 RPM

Size and Weight
460 x 131 x 351 mm (WxHxD), 13 kg (net)

n/c Piano/Silver MSRP 4.990 € (incl. VAT)

n/c Acacia/Brass MSRP 5.990 € (incl. VAT)

incl. VPO-175 +1.000€ (incl. VAT)



RPM LINE

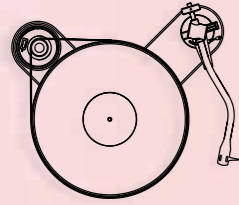

Less vibration through droplet-form

The RPM Line consists of our droplet-form turntables. This kind of form is known for less vibrations due to its build nature. The RPM Line also uses fully decoupled and separate motors for better sound.



RPM 1 Carbon



Manual turntable with 8,6" S-shape carbon tonearm

Cartridge Ortofon 2M Red Elliptical stylus (MM)	Tonearm 8,6" S-shape made from carbon/alu	Drive Principle Precision belt drive decoupled motor	Speed 33/45 RPM manual change
Chassis and Platter High-gloss painted MDF, inverted platter bearing for reduced rumble	Output Phono Out	Included Items Felt mat, power supply, Connect it E (RCA cable)	Size and Weight 380 x 110 x 350 mm (W x H x D) 3.8 kg (net)

Colour Options    High-Gloss white, black, red: 699 € incl. 2M Red

RPM 3 Carbon



Manual turntable with 10" S-shape carbon tonearm

Cartridge Ortofon 2M Silver Elliptical stylus (MM)	Tonearm 10" S-shape made from carbon/alu	Drive Principle Precision belt drive decoupled motor	Speed 33/45 RPM manual change
Chassis and Platter High-gloss painted MDF, inverted platter bearing for reduced rumble	Output Phono Out	Included Items Felt mat, power supply, Connect it E (RCA cable)	Size and Weight 422 x 118 x 373 mm (W x H x D) 5.5 kg (net)

Colour Options    High-Gloss white, black, red: 999 € incl. 2M-Silver

RPM 5 Carbon



Manual turntable with 9" Evo tonearm

Cartridge Ortofon 2M Bronze Elliptical stylus (MM)	Platter Acrylic	Drive Principle Precision belt drive decoupled motor	Speed 33/45 RPM manual change
Chassis A low resonance MDF/ carbon chassis holds a inverted platter bearing with ceramic ball.	Tonearm 9" cc EVO Carbon MM & MC capability TPE damped counter-weight	Included Items Felt mat, power supply, Record clamp, Connect it E (RCA cable)	Size and Weight 430 x 150 x 323mm (W x H x D) 8.0 kg (net)
	Output Phono Out		

Colour Options    High-Gloss white, black, red: 1.999 € incl. 2M-Bronze

Prices (Suggested Retail Prices) are only for orientation and can differ depending on local taxes. Prices, technical data and release date without engagement.

RPM 9 Carbon



Highend turntable with 9" Evo tonearm

Cartridge Ortofon Quintet Bronze Nude fine line stylus	Platter 7.2 kg aluminium	Drive Principle Precision belt drive decoupled motor	Speed 33/45 RPM electronic change
Chassis MDF with hard resin coated steel pellets - special complex heat treatment and a carbon surface coating. Holds a inverted platter be- aring with ceramic ball.	Tonearm 9" cc EVO Carbon MM & MC capability TPE damped counter- weight	Included Items Power supply, Connect it 5P-CC (phono cable), Record puck	Size and Weight 440 x 180 x 325 mm (W x H x D) 16.5 kg (net)

Colour Options  with Quintet Bronze: 3.990 €

RPM 10 Carbon



Highend turntable with 10" Evo tonearm

Cartridge Ortofon Cadenza Red Nude fine line stylus on alu cantilever	Platter 14.4 kg aluminium	Drive Principle Precision belt drive decoupled motor	Speed 33/45 RPM electronic change
Chassis MDF with hard resin coated steel pellets - special complex heat treatment and a carbon surface coating. Holds a inverted platter be- aring with ceramic ball.	Tonearm 10" EVO Carbon MM & MC capability TPE damped counter- weight	Included Items Ground it Carbon, record puck, power supply, Connect it CC (Model 5P-CC)	Size and Weight Turntable: 480 x 210 x 330 mm (W x H x D) 22.0 kg (net) Ground it: 500 x 70 x 400 mm (W x H x D) 14,5 kg

Colour Options   with Cadenza Red 5.990 €



X1 B

(Balanced)

Cartridge

Ortofon Pick it PRO B
Elliptical stylus (MM)

Chassis

Massive and heavy
MDF, painted with 8
layers and hand-
polished finish

Platter

1.5 kg heavy acryl
Stainless steel-bearing
with soft brass bushing

Tonearm

8,6" carbon/alu sand-
wich tonearm, kardan
ultra-low friction 4 pin
point precision bearing,
TPE damped counter-
weight

Output

XLR / Phono out

Drive Principle

Drive belt on sub-platter,
isolated motor for less
vibration and noise

Feet

Height adjustable,
black aluminium

Included Items

Dust cover, felt mat,
power supply,
Connect it E (RCA cable)

Speed

33/45/78 RPM
electronic switch

Size and Weight

415 x 125 x 335 mm
(W x H x D), 5,9 kg (net)

Colour Options



High Gloss White, High Gloss Black or Walnut

X1 B (Pick it PRO B)

1.099 €



Mini XLR
Output



X2 B

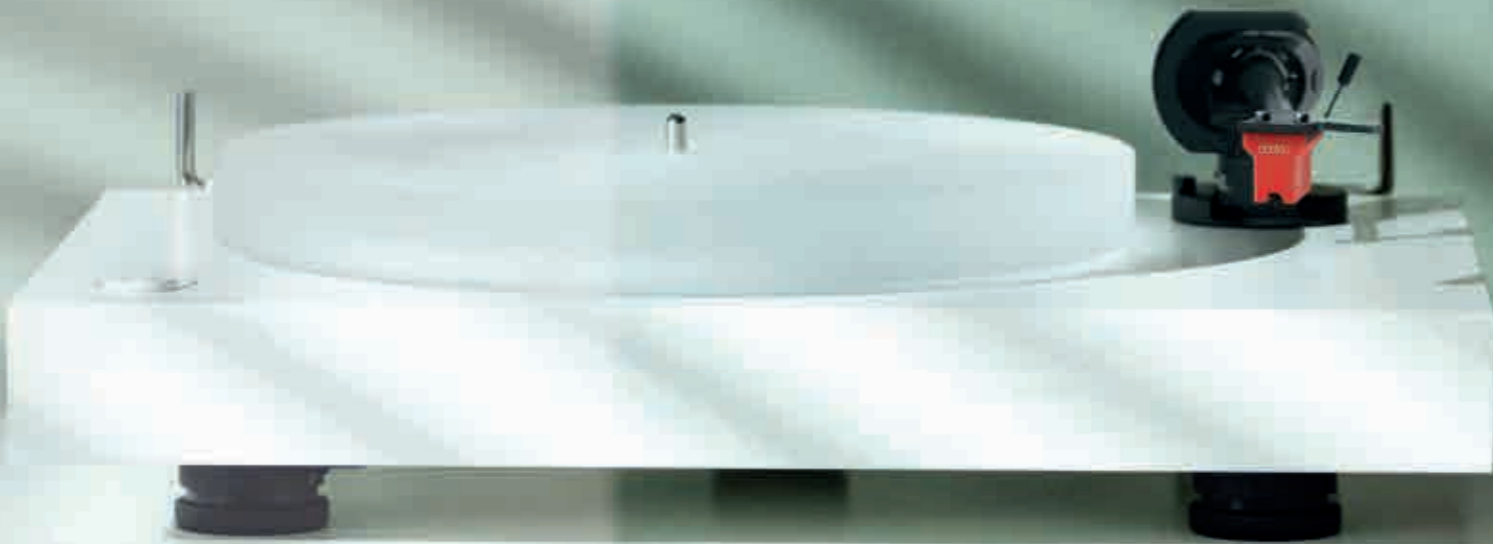

Cartridge

Ortofon Quintet Red
MC Stylus

Chassis

Massive and heavy
MDF, painted with 8
layers and handpolis-
hed finish in, high-
gloss black

Platter

2 kg heavy acryl platter
Stainless steel-bearing
with soft brass bushing

Tonearm

9" carbon/alu sandwich
tonearm, kardan ultra-
low friction 4 pin point
precision bearing, TPE
damped counterweight

Output

XLR / Phono out

Drive Principle

Drive belt on sub-platter,
isolated motor for less
vibration and noise

Feet

Height adjustable,
black aluminium

Included Items

Dust cover, felt mat,
power supply,
Connect it E (RCA cable)

Speed

33/45/78 RPM
electronic switch

Size and Weight

460 x 150 x 340 mm
(W x H x D), 9 kg (net)

Colour Options



Satin White, Satin Black, High-Gloss Black, Walnut

X2 B (Quintet Red)

1.699 €

X2 B (Sumiko Ranier US version)

1.399 €

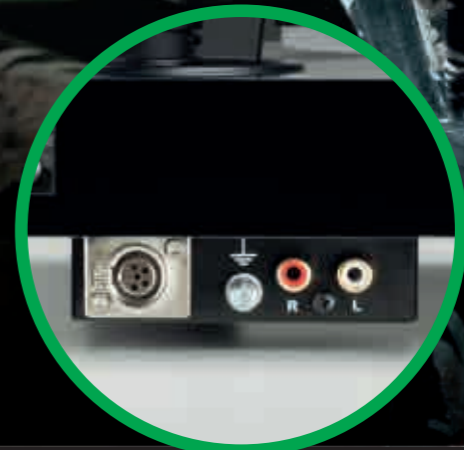



X8

Cartridge

Ortofon Quintet Blue MC Cartridge

Chassis

The X8 inherited the massive MDF chassis and the top-of-the-line Pro-Ject 9cc EVO carbon tonearm from its larger siblings.

Platter

TPE damped, mass-loaded platter precision lathed from a single aluminium block and finely balanced.

Tonearm

Pro-Ject 9cc Evo carbon tonearm

Output

5P/Phono Out

Drive Principle

Belt drive with AC motor with DC driven AC generator

Feet

Three height adjustable damped aluminium feet guarantee the perfect stand.

Included Items

Dust cover, power supply, Connect it E (RCA cable)

Speed

33/45 RPM electronic switch

Size and Weight

465x150x350 mm (WxHxD); 15 kg

Colour Options



X8 (Sumiko Moonstone US version)

2.199 €

X8 (Ortofon Quintet Blue)

2.499 €



www.project-audio.com/x8





XA B

Cartridge
Pick it PRO Balanced

Chassis
Acoustically inert transparent acrylic chassis

Included Items
Dust cover, felt mat, power supply, Record Puck E, Connect it E (RCA cable)

Platter
Precision aluminium platter TPE damping

Tonearm
10" one-piece alu tonearm with VTA adjustability

Output
5-pin DIN output

Drive Principle
Drive belt on sub-platter, isolated motor for less vibration and noise

Feet
Height adjustable, black aluminium

Speed
33/45 RPM electronic switch

Size and Weight
460 x 130 x 340 mm (W x H x D) 6,3kg net

Colour Acrylic Chassis

1.299 €



6 PerspeX Balanced

Cartridge
optional with
MC 3

Chassis
Acrylic Plinth, Sub-
chassis made from
Corian with magnetic
suspension.

Platter
Acoustically inert
sandwich construction
of platter with combi-
nation of MDF and vinyl
layer as mat,

Tonearm
tonearm 9 cc Evolution,
bearings with ABEC 7
ballraces

Output
RCA/Mini XLR

Drive Principle
Belt drive with AC
motor with DC driven
AC generator

Feet
Height adjustable,
black aluminium

Included Items
Dust cover, record
clamp, power supply,
spirit level, Connect it E
(RCA cable)

Speed
33/45 RPM
electronic switch

Size and Weight
460 x 183 x 365 mm
(W x H x D), 9,3 kg (net)

Acrylic Plinth 2.390 € without cartridge, 2.799 € with Pick it MC3

6 PerspeX Balanced

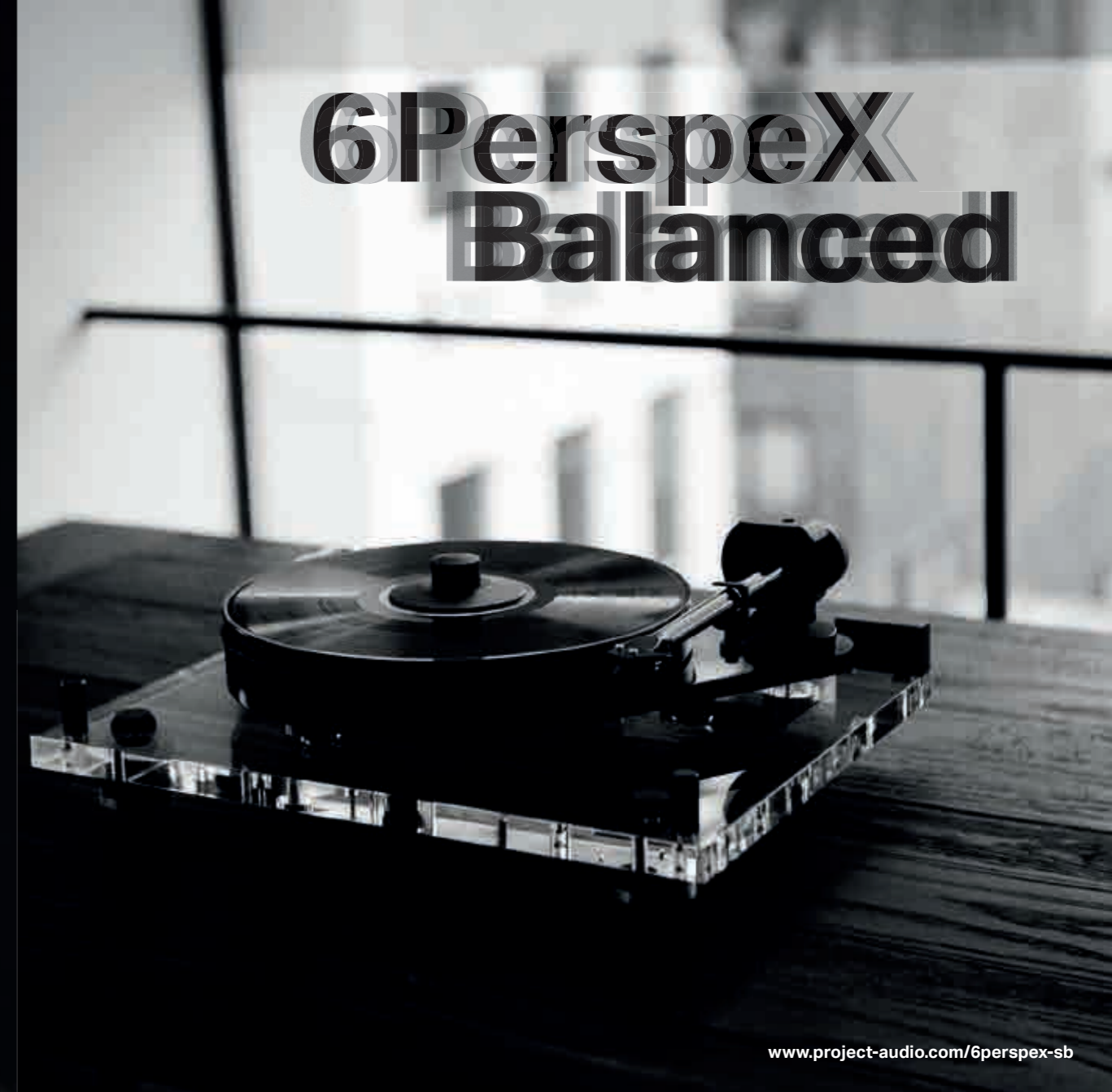

www.project-audio.com/6perspex-sb

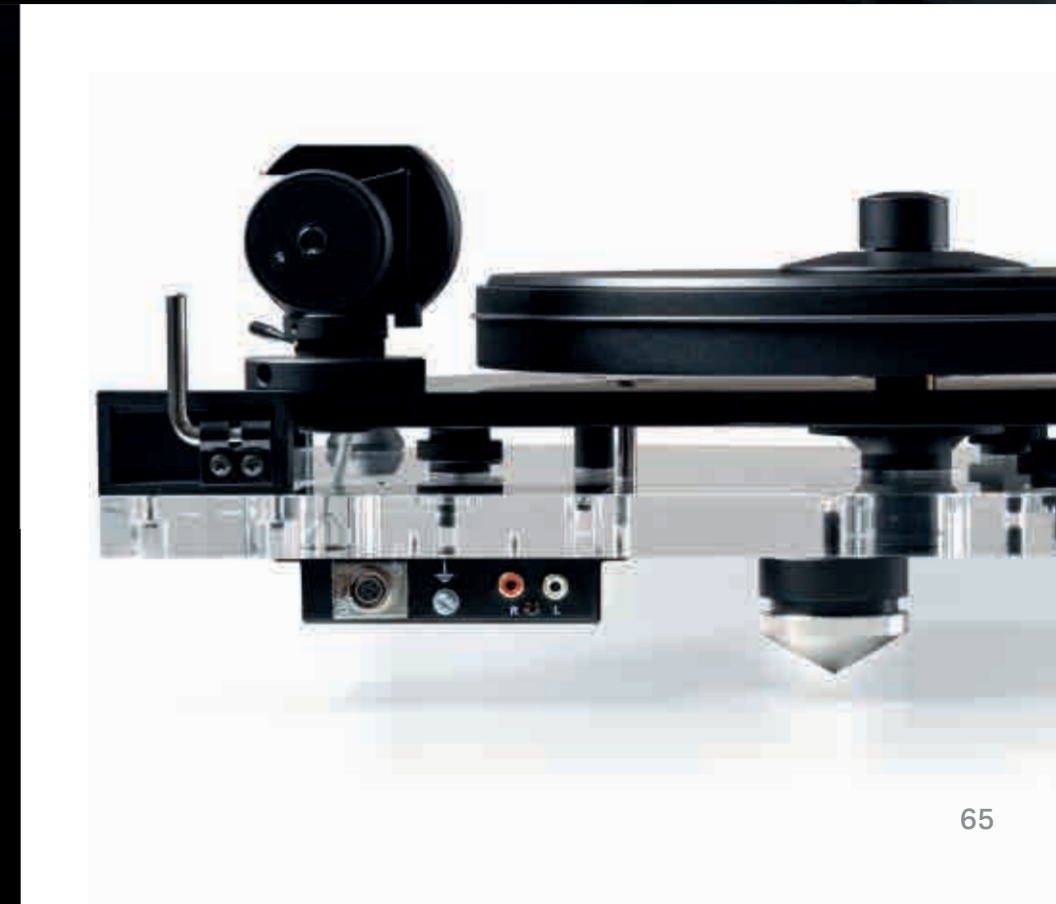

Xtension 9 Evolution

The Best In Class - Superlative Vinyl Performance

Xtension 9 Evolution incorporates all our turntable design experience. Choose from our various finish options, either luxury hand painted colours or real wood veneers.

[Configure on our website >](#)



Finish - High Gloss Black

Choose from two hand-painted and seven real wood veneer finishes.



Tonearm - EVO 9 CC HG

Pick your favourite EVO tonearm type.

→ EVO 9 CC Black	→ EVO 9 CC HG +€500.00
→ EVO 9 AS Black +€300.00	→ EVO 9 AS HG +€1,000.00
→ EVO 9 CA PREMIUM BLACK +€700.00	→ EVO 9 CA PREMIUM HG +€1,200.00
→ EVO 9 AS PREMIUM Black +€1,400.00	→ EVO 9 AS PREMIUM HG +€1,500.00

Cartridge

→ Pick it MC3 +€599.00	→ Pick it DS2 MC +€650.00	→ Pick it MC9 +€700.00
------------------------	---------------------------	------------------------

Phono Cable - Phono DS SP / RCA

→ Phono DS SP / RCA	
→ Phono DS SP / XLR +€219.00	
→ Phono RS SP / XLR +€799.00	
→ Phono DS SP / mini XLR	
→ Phono RS SP / RCA +€750.00	

Total: € 3,799.00

Premium Features

Superior Platter

Alu, TPE & Vinyl

Precision aluminium platter with TPE damping ring inside. The vinyl layer on top builds the best surface for your records.



Hi-Tech Feet

Magnetic decoupling

Three powerful magnetic feet effectively decouple the turntable & let it float over the surface.



33 / 45 RPM

Precision motor control

The precision DC-driven AC generator powers the motor for enhanced speed stability. Easily change speeds with the push of a button.



Silent Bearing

Special technology

The heavyweight platter spins on an inverted ceramic ball bearing with a magnetic support to reduce bearing noise and resonance to an absolute minimum.



MAGNETIC MAIN BEARING

To ensure stable speeds a proper platter bearing is needed. The Xtension 9 Evolution uses a special technology.

The heavyweight platter spins on an inverted ceramic ball bearing with a magnetic support to reduce bearing noise and resonance to an absolute minimum. Which this solution we are able to relieve the main bearing and ensure that the platter runs ultra-silently.



Xtension 10 Evolution



Highend turntable with 10" Evo tonearm

<p>Cartridge Ortofon Cadenza Red Nude fine line stylus on alu cantilever</p> <p>Chassis MDF with hard resin coated steel pellets - special complex heat treatment and a carbon surface coating. Holds a inverted platter be- aring with ceramic ball.</p>	<p>Platter 10,3 kg aluminium</p> <p>Tonearm 10" EVO Carbon MM & MC capability TPE damped counter- weight</p> <p>Output 5P/Phono Out</p>	<p>Drive Principle Precision belt drive decoupled motor</p> <p>Included Items Heavy weight record clamp, dust cover, power supply, spirit level, gloves, Connect it CC (Modell 5P-CC)</p>	<p>Speed 33/45/78 RPM electronic change</p> <p>Size and Weight 480 x 235 x 400 mm (W x H x D) 26 kg (net)</p>
---	--	---	---

Colour Options 

White, Black, Red, Olive, Mahagoni, Walnut, Palisander, Eucalyptus: 4.500 € n/c | incl. Cadenza Red: 5.500€

High Gloss Walnut Burl, Satin Walnut Burl: 5.999 n/c | incl. Cadenza Red: 6.500 €

Xtension 12 Evolution



Highend turntable with 12" Evo tonearm

<p>Cartridge n/c</p> <p>Chassis MDF with hard resin coated steel pellets - special complex heat treatment and a carbon surface coating. Holds a inverted platter be- aring with ceramic ball.</p>	<p>Platter 14.4 kg aluminium</p> <p>Tonearm shown with 12" EVO HG Premium MM & MC capability TPE damped counterweight</p> <p>Output 5P/Phono Out</p>	<p>Drive Principle Precision belt drive decoupled motor</p> <p>Included Items Heavy weight record clamp, dust cover, power supply, spirit level, gloves, Connect it CC (Modell 5P-CC)</p>	<p>Speed 33/45/78 RPM electronic change</p> <p>Size and Weight 550 x 550 x 560 mm (W x H x D) 33 kg (net)</p>
---	---	---	---

Colour Options 

Black, Olive, Mahagoni, Walnut: 4.999 € n/c

High Gloss Walnut Burl, Satin Walnut Burl: 6.500 € n/c



Chassis

MDF with hard resin coated steel pellets - special complex heat treatment and a carbon surface coating.

Signature 10

An uncompromising high-end turntable combining mass-loading with magnetically-floating turntable principles.



Highend turntable with single-pivot tonearm.

Cartridge
not included (n/c)

Chassis
Piano-lacquer chassis with magnetic decoupling or veneered with walnut burl satin or high-gloss.

Platter
10.1 kg heavy acryl Stainless steel-bearing with soft brass bushing

Signature Tonearm
Single-pivot tonearm in high gloss metal surface.

Output
5P/Phono Out

Drive Principle
Motor control system for perfect speed stability.

Feet
Height adjustable, black aluminium

Included Items
Connect it CC (Modell 5P-CC)
Record puck, gloves, spirit level...

Speed
33/45 RPM
electronic switch

Size and Weight
475 x 195 x 354 mm (W x H x D)
22,6 kg (net)

Colour Options  Piano White, Piano Black, Olive, Mahagoni: 6.999 € n/c
High Gloss Walnut Burl, Satin Walnut Burl: 7.999 € n/c

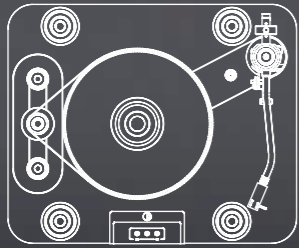

Signature 12.2

Highend turntable

MSRP 12.000 € (incl. VAT)

- **NEW** 3-point pivot bearing construction
- **NEW** modified counterweight system
- **NEW** motor mounting avoids vibrations
- **NEW** round shaped MDF chassis
- **NEW** adjustable from the top spring loaded feet
- Heavyweight mass-loaded design
- Magnetically decoupled main platter
- Resonance-optimised alloy
- Inverted main bearing with ceramic ball
- Flywheel belt drive
- High gloss metal surface
- Handmade in Europe

Speed: 33, 45 electronic speed change
Actuation principle: Flywheel belt drive
Motor control system: Precision generator
Platter: 10,55 kg magnetically decoupled
Main bearing: ceramic (ball/plate)
Tonearm: 12" aluminium - 3-pint-pivot
Effective arm length: 304,8 mm
Effective arm mass: 21,5 g
Dimensions: 580x 220 x 480mm (WxDxH)
Weight: 37 kg



The Dark Side of the Moon

Not only the music of the album „The Dark Side Of The Moon“ is truly iconic, also the artwork itself. It shows an enigmatic prism which reflects beams of light into space. A magical and mystical theme which illustrates the band's complex sound world.

€ 1.799



ARTIST COLLECTION

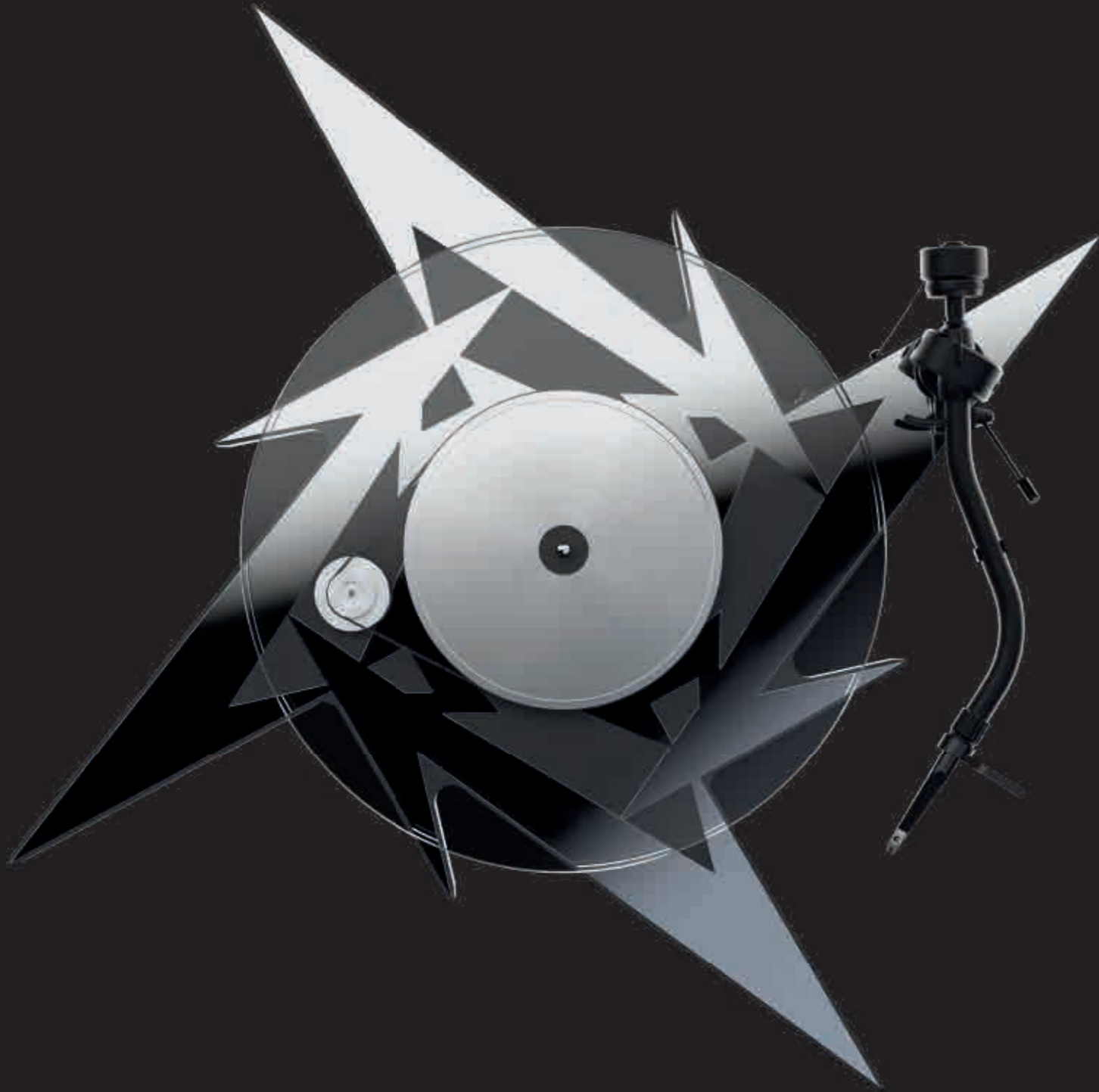

Metallica Turntable

When you rock vinyl on this deck – Nothing Else Matters.

1.499 €

Prices (Suggested Retail Prices) are only for orientation and can differ depending on local taxes. Prices, technical data and release date without engagement.



Essential III Sgt. Pepper's Drum

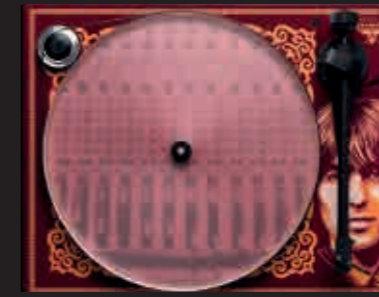

George Harrison Recordplayer



2Xperience The Beatles White Album



The Beatles 1964 Recordplayer

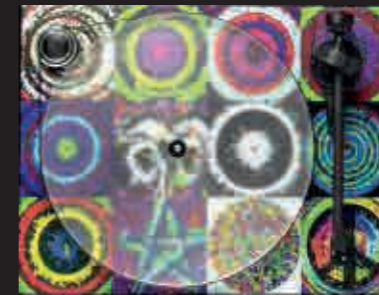

Ringo Starr Peace & Love Turntable



2Xperience Sgt. Pepper



Rolling Stones Recordplayer

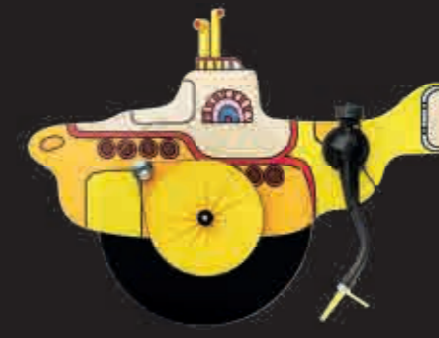

The Beatles Yellow Submarine



Hans Theessink Recordplayer



PS00 - Frida by Parov Stelar

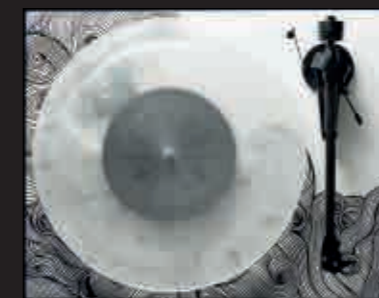

PS01 - Wave by Parov Stelar



Essential III Demon by Parov Stelar



Beatles Singles Turntable



Deladap Turntable



Hard Rock Cafe Turntable

HIFI ELECTRONICS



BT Box E HD



- Wireless music streaming in high definition • BT 5.0 + aptX and aptX HD • Easy to install and use • Fast auto pairing (3 to 5 seconds) • Up to 8 different BT sources are memorized • Works within a range of approximately 10 meters • RCA analogue and Toslink digital outputs (switchable) • Outboard power supply included • Black or White casing

159 €

DAC Box E



- 24bit / 192kHz D/A conversion • Co-axial (RCA) & optical (Toslink) S/PDIF input • SMD circuitry • Special low noise components • Internal metal shielding • Small size allows installation close to source • Gold plated RCA connection sockets • Outboard power supply included • Black or White casing

109 €

Optical Box E Phono



- Multi-purpose phono preamplifier with A/D conversion and 2 output options: Line level and digital optic! • Especially for use with devices with no analogue input such as home cinema receivers, soundbars etc • Analogue RCA and digital optic output work simultaneously • Works as input extender (2>1) or output splitter (1>2) • 2 Inputs: 1 Phono and 1 Line In • Suitable for MM cartridges • Precise RIAA equalisation • Low noise circuitry • Internal metal shielding • Gold-plated RCA inputs • Outboard power supply included • Black or White casing

179 €

Phono Box E



- Amplification and RIAA equalisation for MM cartridges • Design principle inspired by Dr. Sykora • SMD circuitry • Special low noise components • Internal metal shielding • Small size allows installation close to record player • Gold plated RCA connection sockets • Outboard power supply included • Dimension: 120x32x100/106 mm (WxHxD/D with sockets) • Weight: 269 g without power supply • Black or White casing

79 €

Phono Box E BT 5



- Connect your turntable wirelessly • Bluetooth 5.2 streaming with aptX Adaptive and HD support • 2 Inputs: 1 Phono and 1 Line Input • Suitable for MM cartridges • Precise RIAA equalisation • Use analogue RCA & BT output simultaneously • Low noise circuitry • Internal metal shielding • Gold-plated RCA connectors • Outboard power supply included • Black or White casing

159 €

Record Box E



- Amplification and RIAA equalisation for MM & MC • Design principle inspired by Dr. Sykora • Digitalisation of vinyl for recording direct to USB with suitable recording programs • Automatic recognition, no additional drivers needed • Runs on Windows®, Mac OS® & Linux operating systems • SMD circuitry with special low noise components • Internal metal shielding • Small size allows installation close to record player • Gold plated RCA connection sockets • Outboard power supply included • Black or White casing

159 €

CD Box E



- Aluminium frontpanel with aluminium buttons • Rigid metal chassis protects against interference • True Red Book CD-DA drive in shock-proof mounting • Slot-in mechanism • High-quality DAC for precise playback of Audio-CDs • RCA line level analog output • Coaxial S/PDIF digital output • Remote control included • Available in silver or black • Dimension: 206 x 55 x 153 mm

279 €

Phono Box MM



- Metal case shields the electronics from vibrational and electromagnetic interference
- Special low-noise ICs used
- Optimal channel separation through dual-mono circuitry
- Gold plated RCA connection sockets
- DC power supply (< 1 watt standby power)
- Amplification and RIAA equalisation for MM cartridges
- Small size allows installation close to record player
- Dimensions: 107x30x75 mm (WxHxD)
- Weight: 280g without power supply

● 79 €

Phono Box



- Preamplifier for MM or MC with switch on rear panel
- Best buy classic
- DC power supply (< 1 watt standby power)
- Precise RIAA equalisation
- Low noise ICs
- Output stage with ultra-low impedance
- Gold-plated RCA sockets
- Small size for installation near recordplayer
- Dimensions: 103x36x104 / 115 mm with sockets (WxHxD)
- Weight: 570 g
- Faceplate in silver or black

◐ 99 €



Our Entry Line HiFi Electronics

What is S-Line?

We designed a range of high-end electronic micro components, engineered and manufactured according to the same principles as our acclaimed turntables. The idea is to make the devices as small as possible, but still have breathtaking sound performance.



Head Box S2



- Audiophile headphone amplifier • Suitable for demanding headphones
- 6.35mm and 3.5mm headphone output • Bypass RCA loop output for additional amplifier
- Superior low distortion • Low noise components for ultimate sound performance
- Small footprint • Both outputs usable simultaneously
- Aluminium/metal sandwich casing protects against vibrations and electromagnetic interference
- Available in silver or black

159 €

Head Box S2 Digital



- Headphone amplifier and DAC with 32bit and DSD256 support
- High end ESS Sabre ESS9038 DAC
- Proprietary clock circuitry design
- Organic polymer capacitors and thin film miniMELF resistors
- 32bit / 768kHz decoding
- DSD64, DSD128 & DSD256 (DSD over PCM)
- Up to 24bit/192kHz for optical & coax inputs
- 5 selectable digital filter characteristics
- 1 proprietary optimum transient digital filter
- Headphone output on the front (6.3mm)
- Synchronization of all internal oscillators
- Jitter as low as 100 Femtoseconds!
- Gold plated four layer PCB
- Available in silver or black

329 €

Pre Box S2 Analogue



- Stereo Line preamplifier
- Advanced circuitry with premium components
- Neutral sound with superior low noise floor
- 3 Stereo Line inputs
- 1 fixed line output
- 1 pre output
- Motorised volume control
- SMD for short signal paths
- Low output impedance for low loss with long cables
- Gold-plated connections
- Remote control for on/off, input select, volume
- Trigger outputs for Amp Box S2
- Alu/Metal casing protects against vibration and interference
- Weight: 405 g without power supply
- Available in silver or black

299 €

Amp Box S3



- Micro audiophile stereo power amplifier
- The new Amp Box S3 offers one stereo RCA input and delivers powerful and room-filling sound to every loudspeaker.
- The new PCB concept & sophisticated topology achieves less distortion and a better signal to noise ratio.
- We designed this amp to match the sound characteristics of a tube amplifier as close as possible.

299 €

Stereo Box S3 BT



- Ultra compact integrated amplifier with high quality AptX HD Bluetooth input!
- 2 x 40 watts @ 4 ohms output power
- BT 5.0 with aptX HD capability (24-bit, up to 48kHz)
- Ultra compact integrated amplifier
- Analogue volume control with motor driven potentiometer
- 2 pair RCA line inputs
- Variable output for subwoofer or second zone amp
- Gold plated RCA connectors
- Isolated speaker outputs
- IR remote control included
- Rigid aluminium casing protects against interference
- Available in black or silver

399 €

MaiA S3



The MaiA (My Audio Integrated Amplifier) S3 is the all in one solution for your hifi system. Not only the circuit design was reworked, also the case has been significantly changed and the MaiA S3 uses our new S3 case. Due to the bigger size we were able to improve the circuit board layout in terms of electromagnetic interference. With its 8 inputs you are ready for any kind of source device.

- **NEW** Bluetooth 5.0 - aptX HD capable (24-bit, up to 48kHz)
- 2 x 40 watts @ 4 ohms
- Dual mono design principle
- 8 inputs (5x analog, 3x digital & 1x wireless BT)
- Cirrus Logic CS4344 24bit/192kHz Multi-bit Delta Sigma
- S/PDIF inputs support up to 24bit and 192kHz
- Phono MM, MI + high output MC input
- Analogue volume control with motor driven potentiometer
- 6,3mm jack headphone output
- Variable output for subwoofer or second zone amp

599 €

Phono Box S2



- Audiophile performance
- Dual mono configuration
- Audiophile-grade amplification modules
- Audiophile-grade polypropylene WIMA capacitors
- Precise RIAA equalisation
- Switchable Subsonic filter -12dB @ 20Hz
- Switchable input impedance/capacitance
- 4 adjustable gain levels
- Outstanding sound quality
- Weight: 570 g net
- Colour options: silver or black

179 €

Phono Box S2 Ultra



- Audiophile performance
- No Operational Amplifiers used
- Audiophile-grade polystyrene capacitors
- Precise RIAA equalisation
- Switchable Subsonic filter -18 dB @ 20Hz
- Switchable input impedance/capacitance
- 4 adjustable gain levels
- Outstanding sound quality
- Weight: 570 g net
- Colour options: silver or black

249 €

Phono Box S3 B



Our Phono Box S3 B comes in a complete new casework. Due to the bigger case, we were able to bring new features into our S3 phono preamplifier. The new steel & aluminium chassis with full aluminium buttons brings very good rigidity and splendid isolation against interferences.

- **NEW** 5-pin mini XLR balanced input
- **NEW** balanced XLR outputs
- **NEW** fully symmetrical & discrete gain stage
- **NEW** easy settings adjustment on the face-plate
- MM & MC capable
- Dual mono design
- Semi-passive RIAA equalization
- Superior low noise / low distortion

399 €

Tube Box S2



- Suitable for MM and MC cartridges
- Precise RIAA equalisation in two parts, passive/active
- Fully discrete circuit design without OpAmps
- 2x ECC83 tubes (replaceable)
- Front-sided Subsonic filter button
- Front-sided Gain control
- Ultra low noise circuitry with FET input stage
- Dual mono circuitry for optimized channel separation
- Polystyrene capacitors used where possible
- Gold-plated RCA in-and outputs
- External power adaptor and multiple internal power supplies
- Well-filtrated high-voltage anode power supply
- Dimensions (with sockets & Tubes): 103x73x131 mm (WxHxD)
- Weight: 410 g without power supply
- Colour options: silver or black

399 €

PHONO

Vinyl NRS Box S3



- Audiophile performance
- No Operational Amplifiers used
- Audiophile-grade polystyrene capacitors
- Precise RIAA equalisation
- Switchable Subsonic filter -18 dB @ 20Hz
- Switchable input impedance/capacitance
- 4 adjustable gain levels
- Outstanding sound quality
- Weight: 570 g net
- Colour options: silver or black

329 €

Power Box S3 Phono



- Cleanest power for your phono setup! The power supply is a very important part of the audio path and significantly contributes to the sonic quality of an audio product.
- Superlative audiophile power supply
- No disturbing interferences through mains
- 1 x 18V output for phono stages
- 1x15V output for turntables
- Low noise components
- Full aluminium/metal casework silver or black

179 €

Tuner Box S3 DAB +



- FM, DAB+ tuner and internet radio
- Internet radio with worldwide stations & podcasts
- 6,3mm jack headphone output on the front
- Easy & intuitive controls
- Auto play of last station when turned on
- RCA, coaxial and optical output
- Remote control included
- Full function IR remote control
- Frequency response: 20 Hz - 20 kHz
- Headphone amplifier: 2x 75mW at 32ohm (1%THD)
- Headphone output: 6,3mm jack
- WiFi Standards: WiFi 802.11 b/g/n
- Full aluminium/metal casework
- Weight 940 g
- Colour options: silver or black

● ● 449 €

CD Box S3



The CD Box S3 is our first product of the new S3 line. In contrast to DVD or Blu-ray Disc players, a pure CD player is frequently better in playback of stereo CDs. The drive in the CD Box S3 enables 1:1 bit-accurate CD playback. The new DAC chip provides the best digital analog conversion with a bit depth & sampling rate up to 32bit/384kHz. The slot in mechanism smoothly draws in the CD and after a few seconds it is ready to play.

- NEW 1,54" display with colour inversion function
- Slot-in mechanism
- 32bit/384kHz DAC for precise playback of Audio-CDs
- RCA line level analog output
- Coaxial S/PDIF digital output

● ● 449 €

DAC Box S2 +



- High end ESS Sabre ESS9038 DAC
- Proprietary clock circuitry design
- Organic polymer capacitors and thin film miniMELF resistors
- 32bit / 768kHz PCM support
- DSD64, DSD128 & DSD256(DSD over PCM)
- Up to 24bit/192kHz for optical & coax inputs
- 5 selectable digital filter characteristics
- 1 proprietary optimum transient digital filter
- Synchronization of all internal oscillators
- Jitter as low as 100 Femtoseconds
- Gold plated four layer PCB
- Weight: 355g without power supply
- Full alu/metal sandwich casing
- Colour options: silver or black

● ● 299 €

Pre Box S2 Digital Edition 23



- Dual mono construction
- High end ESS Sabre ESS9038 dual DAC
- Proprietary clock circuitry design
- Organic polymer capacitors and thin film miniMELF resistors
- MQA hardware decoding
- DSD64, DSD128, DSD256 & DSD512 (DoP, DSD512 native)
- Up to 24bit/192kHz for optical & coax inputs
- Headphone output on the front (6.3mm)
- Synchronization of all internal oscillators
- Jitter as low as 100 Femtoseconds
- Gold plated four layer PCB
- Weight: 366 g (without power supply)
- Full alu/metal sandwich casing
- Colour options: silver or black

● ● 449 €



Control it Pre Box S2 Digital

69 €

SOURCES

BT Box S2 HD



- Wireless music streaming with almost CD-quality
- Bluetooth 3.0
- Supports aptX & SBC codecs
- Easy to install and use
- Fast auto pairing (3 to 5 seconds)
- Up to 8 different Bluetooth sources are memorized
- Works within a range of approximately 10 meters
- RCA stereo analogue and optical Toslink output
- Outboard power supply included
- Antenna included
- Dimensions (with sockets): 116x37x108 mm (WxHxD)
- Weight: 320 g
- Colour options: silver or black

● ● 199 €

Stream Box S2 Ultra



- High resolution network bridge
- Audio optimized USB A output
- Multi-room enabled
- Dual USB A input for external storage
- TIDAL supported
- Spotify Connect
- Network-enables any modern DAC with USB input
- Internet radio
- DLNA enabled
- Bypasses all audio formats to the DAC
- Cleans up the audio signal from a PC
- Roon ready
- Shairport
- Bluetooth (for control)
- Uses dedicated power supplies
- HDMI video output
- Controllable via smart devices and PC/Laptop
- New control app
- Ethernet and WiFi connectivity
- Weight: 375 g (without power supply)
- Colour options: silver or black

● ● 699 €

Stream Box S2



- Compact multiroom streamer
- 24/192 streaming client
- Spotify Connect, TIDAL
- Tuneln, iHeartRadio internet radios
- UPnP, DLNA support
- Multi-room
- Stereo pairing
- ESS9023 DAC
- WAV, ALAC, FLAC, MP3, APE, AAC
- Line Input
- Fixed, variable analogue & optical outputs
- Shairport
- WiFi 802.11 b/g/n
- Free control App „Pro-Ject Stream S2“ (iOS/Android)
- Full aluminium/metal casework
- Weight 375 g (without power supply)
- Colour options: silver or black

● ● 229 €

MC Step Up Box S3



- Step-up transformer for MC cartridges
- Sound upgrade for your MC cartridge
- Fully passive signal path without power supply
- Superior sound quality
- 1:16 transformer ratio
- Transformer with mu metal shielding
- Input impedance matching 10 or 100 Ohms
- Dual mono design principle
- Highest channel separation
- Gold plated RCA terminals
- Solid aluminium casing protects against interference
- Weight: 940g
- Colour options: silver or black

● ● 449 €

Accu Box S2



- Superlative audiophile power transmission
- Accu driven power supply
- No disturbing interferences through mains
- Perfect for all phono electronics
- 1 x 18V output
- 1 x 5V USB A output
- LED indication for charging and mains
- Full aluminium/metal casework
- Weight: 545 g, without power supply
- Colour options: silver or black

● ● 299 €

Control it 1



The new Control it 1 offers all functions you need in your daily HiFi use.

- Modern and lightweight design
- Controls amplifier and CD player
- Pre-programmed system remote
- Replaces standard Box Design IR remotes
- Compatible with many products (see list)
- Dimension: 150 x 40 x 15 mm
- Weight: 70g

● 19 €

MC STEP UP TRANSFORMER

POWER

REMOTE





Stereo Box DS3

AMPLIFIER

- Dual mono design principle • Built-in phono pre-amplifier with MM & MC capability • Other inputs: 3x analogue, 1x Bluetooth • 4th generation Bluetooth with aptX capability & antenna • Volume control with motor driven potentiometer • Headphone output with dedicated amplifier stage • Fixed & variable outputs for subwoofer or second zone amp • Trigger In and Output • IR remote & built-in App Remote Control via Bluetooth • Free Box Control App controls this device & other IR equipment • Magnetic wooden side panels available separately



899 €

Pre Box DS2 analogue

- Analogue RCA inputs • Fixed line level output as well as variable output • Mono subwoofer RCA output • Trigger in/out • RCA Line Level solid state output • Ultra linear circuit • Coupling-capacitor free signal path • Ultra low noise floor • IR remote control supplied • Magnetic wooden side panels available separately



549 €

Amp Box DS2

- Superior Class D modules • Impressive signal spectrum and lower distortion • High efficiency from mains to audio power • Low heat emission • Stereo level input (RCA) • Loop output (RCA) • Isolated speaker outputs • Trigger input & loop out • Elegant aluminium - metal sandwich casing • 2x140/100 watts 4/8 Ω • Weight: 1670 g (Alu) without power supply; 2130 g (Wood) without power supply • Magnetic wooden side panels available separately



699 €



MaiA DS3



The MaiA DS3 (My audio integrated Amplifier) is our new reworked all-in-one compact amplifier solution. It combines both, analogue and digital inputs to suit all different sources. With its 140 watts per channel at 4 ohms you can easily power your favourite speakers. MaiA DS3 is handmade in Europe and available in an either black or silver finish. Magnetic wooden side panels available separately

- Stereo integrated amplifier with 9 inputs
- Powerful 140 watts per channel at 4 ohms
- PCM 1795DB 32bit/192kHz Delta-Sigma DAC
- BT 5.0 receiver with aptX, aptX HD, A2DP profile
- 9 different analog & digital inputs
- Sub output & variable output
- Phono input - MM & MC capable
- Dual mono design
- XMOS asynchronous USB 24bit/192kHz
- DSD capability (DSD64, DSD128; DSD256)
- Headphone output 2 x 430mW at 32ohm (1%THD)
- Trigger in- & output

○ ● 1.199 €

CD Box DS3



- HiRes capable CD player and DAC
- PCM up to 32/384 and DSD256 (DoP) - via USB input
- Four digital inputs (2x optical, coaxial, USB B)
- Two digital outputs (optical, coaxial)
- Line Level output (RCA)
- Excellent 4-layer suspended CD transport
- Blue Tiger CD-80 servo board for 1:1 CD playback
- Luxurious slot-in mechanism
- DC power supply (<1watt standby power consumption)
- High contrast dot-matrix display
- Trigger in and output
- Solid cabinet protects against vibration and interference
- Magnetic wooden side panels available separately

○ ● 699 €

CD Box DS2 T



- Three digital outputs (Optical, S/PDIF Co-axial and AES/EBU)
- Excellent 4-layer suspended CD transport
- „Blue tiger” servo board for 1:1 CD playback
- Luxurious slot-in mechanism
- DC power supply (<1 Watt standby power consumption)
- High contrast dot-matrix display
- Trigger in and output
- Massive 3 mm aluminium faceplate
- Solid cabinet protects against vibration and interference
- Magnetic wooden side panels available separately

○ ● 649 €

SOURCES

Phono Box DS3 B



The Phono Box DS3 B employs a true fully balanced gain stage design. Connect your turntable either with the 5-pin mini XLR cable or standard XLR cables & profit of the balanced signal path. Symmetrical, or also called balanced, transmissions consist of a hot and a cold (also called + and -) signal. Both signal chains effectively carry the same musical information.

- balanced XLR in- & outputs • 5-pin mini XLR balanced input • fully symmetrical & discrete gain stage • fully passive & discrete RIAA equalisation • fully discrete audio circuitry - NO Op-amps! • MM & MC capable • Balanced & single ended in- & output • Dual mono design • Continuously variable input impedance loading • Most precise MC cartridge matching • Superior low noise / low distortion • Trigger in- & output • Heavy aluminium casing protects against interference • Available in silver or black • Magnetic wooden side panels available separately

● ● 599 €

Phono Box DS2



- Suitable for MM and MC cartridges • Precise RIAA equalisation • Dual mono circuitry for optimized channel separation • Selectable input impedance on front • Selectable input capacitance on front • Low noise ICs • Gold-plated RCA in & outputs • Sandwich alu/metal casing protects from vibrations and electromagnetic interference • Weight: 1320 g (Alu); 1770 g (Wood) without power supply • Magnetic wooden side panels available separately

● ● 349 €

PHONO

Tube Box DS3 B



The Tube Boxes have been an integral part of our product portfolio for many years. Now, the new Tube Box DS3 B adds balanced in- and outputs to the beloved tube amplification. This precision tube phono preamplifier benefits from outstanding circuit technology from Dr. Sykora and uses ultimate components.

- Dual mono balanced tube phono-preamplifier • balanced XLR in- & outputs • more precise cartridge loading options • Precise RIAA equalisation • Ultra low noise circuitry • MM & MC capable • Balanced & single ended in- & outputs • Dual mono design • Continuously variable input impedance loading • Superior low noise / low distortion • Subsonic filter • Aluminium casing protects against interference • Available in silver or black • Magnetic wooden side panels available separately • Tube assembly: 2x E88CC / 6922 • Input impedance: stepless 10-1000 Ohms, fix 47 kOhms • Capacitance: 50 / 150 / 300 / 400 pF • Gain (+6dB using XLR Out): 40 / 45 / 50 / 55 / 60 / 65 dB • Output voltage typically: 500 mV/1kHz at 5mV/1kHz (at 40dB) • Subsonic filter: at 20Hz with 18dB/octave • Weight: 1560g

● ● 899 €



MC Step Up Box DS3 B



PREMIUM BALANCED SOUND UPGRADE

Use the single-ended RCA, or go balanced with the XLR in- and outputs and benefit from a low noise interference free signal transmission. Switch the in- and outputs via the push buttons on the front. Additionally, you can set the gain level either on 24dB or 30dB. As there is no amplification, the MC Step Up Box DS3 B has a remarkable noise performance and a very low level of distortion. The sound with a Step-Up Transformer will be more lively, dynamic and natural.

- Lundahl LL1678 high quality audio transformer
- Balanced in- and outputs
- Fully passive signal path without power supply
- Selectable transformer ratio 24 / 30dB
- Superior sound quality
- Transformer with mu metal shielding
- Dual mono design principle
- Low noise
- Highest channel separation
- Gold plated RCA terminals
- Solid aluminium casing protects against interference
- Heavy aluminium casing protects against interference
- Available in silver or black
- Magnetic wooden side panels available separately

899 €

PHONO

Power Box DS3 Sources



- Universal linear power supply for up to 5 components & 1 turntable
- Purest & cleanest power using non-switching power supply
- Not suitable for integrated & power amplifiers, receivers etc
- Soft start system avoids current inrush in primary winding
- Audio type toroidal transformer
- Main isolating transformer with copper foil shielding
- Secondary voltage rectification with precise regulation
- High filtration capacity (10.000 µF)
- Low ESR capacitors
- Low noise components with surge protection
- Input voltage: AC 115/230V, 50/60Hz IEC C15 connector
- Output voltage ripple: < 1mV
- Magnetic wooden side panels available separately

699 €

Power Box DS2 Amp



- Linear Power Supply Upgrade for Pro-Ject DS2 Series Power Amplifiers
- Replaces original "switching" power supplies
- Significant sound improvement with better dynamic and bass response, improved soundstage
- Big toroidal transformer with copper shielding
- Massive 3 mm aluminium faceplate
- Solid cabinet protects against vibration and interference
- Very low output impedance
- Filtration capability 40.000 uF capacitors low ESR types
- Weight: 4700g (aluminium)
- Magnetic wooden side panels available separately

599 €



Magnetic Side Panels 99 €

Magnetic wooden side panels are now available for all DS2/DS3 products. The magnets inside the panel make the installation very easy & you can always change the style of your HiFi components.





Amp Box RS

AMPLIFIER



- Fully balanced double mono design (Pulse Wave Modulation) • Highly efficient conversion from mains to output power (92%) • 2 ohms drive capability • Tube buffer stage with reference quality • SMD construction for shortest signal paths
- Line level preamp inputs (RCA & XLR) • Top-quality speaker terminals • Metal casing protects against vibration and interference • DC power supply (< 1 Watt standby power) • 2x180/110 watts 4/8 Ω • Dimensions (with sockets): 206x72x220 mm (WxHxD) • Weight: 2120 g without power supply
- Available in silver and black

999 €

CD Box RS2 T

SOURCES



- Ultimate CD Transport • Toploading CD drive • Magnetic clamp • Plays CD Audio, CD-R, CD-RW, Hybrid SACD • Blue Tiger CD-Pro 8 top loading module with suspension system and CD-84 servo board • I2S + Masterclock via HDMI connector • LCD screen displays time, tracks, text (if available) • Gravity design with central mass point • Supports: CD, CD-R, CD-RW (finalized) and Hybrid-SACD (44.1kHz/16bit CD layer only) • Digital outputs: AES3: 1 x balanced (AES/EBU) on XLR connector S/PDIF: 1 x optical (Toslink®) 1 x coaxial (RCA socket) I2S + Master Clock: 1 x HDMI connector • Aluminium IR remote included • Available in a silver or black high-quality aluminium chassis • Dimensions W x H x D (D with sockets): 206 x 78 x 200 (210)mm • Weight: 3.000g without power supply
- Available in silver and black

2.495 €

Pre Box RS2 Digital



- Dual Mono DACs: 2 x ESS9038Q2M 32-bit • PCM 32Bit/768kHz, DSD512 (over USB) • 7 digital inputs: i2S HDMI, AES/EBU, Toslink, S/PDIF coax, USB, Bluetooth
- 2 analogue inputs: unbalanced RCA, balanced XLR • 7 digital + 2 analogue filters • Unbalance RCA, balanced XLR, Headphone outputs • Hardware MQA Decoder and Renderer • Advanced upsampling and re-clocking for MQA and PCM
- Output stage switchable between tube and solid state • i2S + Masterclock connection over HDMI for use with CD Box RS2 T • IR remote in full aluminium chassis included • Available in silver and black

2.499 €

DAC Box RS2



- Dual Mono DACs: 2x ESS9038Q2M • High Quality optionally selectable upsampling of PCM and/or MQA content with proprietary filtering • Advanced re-clocking powered by new XMOS chip with Mult-Core RISC architecture • 6 digital inputs: asynchronous USB, i2S HDMI, AES/EBU, Toslink, S/PDIF coax • Fully balanced double mono design • Output stage switchable between 6922 tube & solid state • Ultra-linear and ultra low noise • New high-quality display with responsive and fast UI design • High quality full Aluminium remote control included
- Available in silver and black

2.099 €

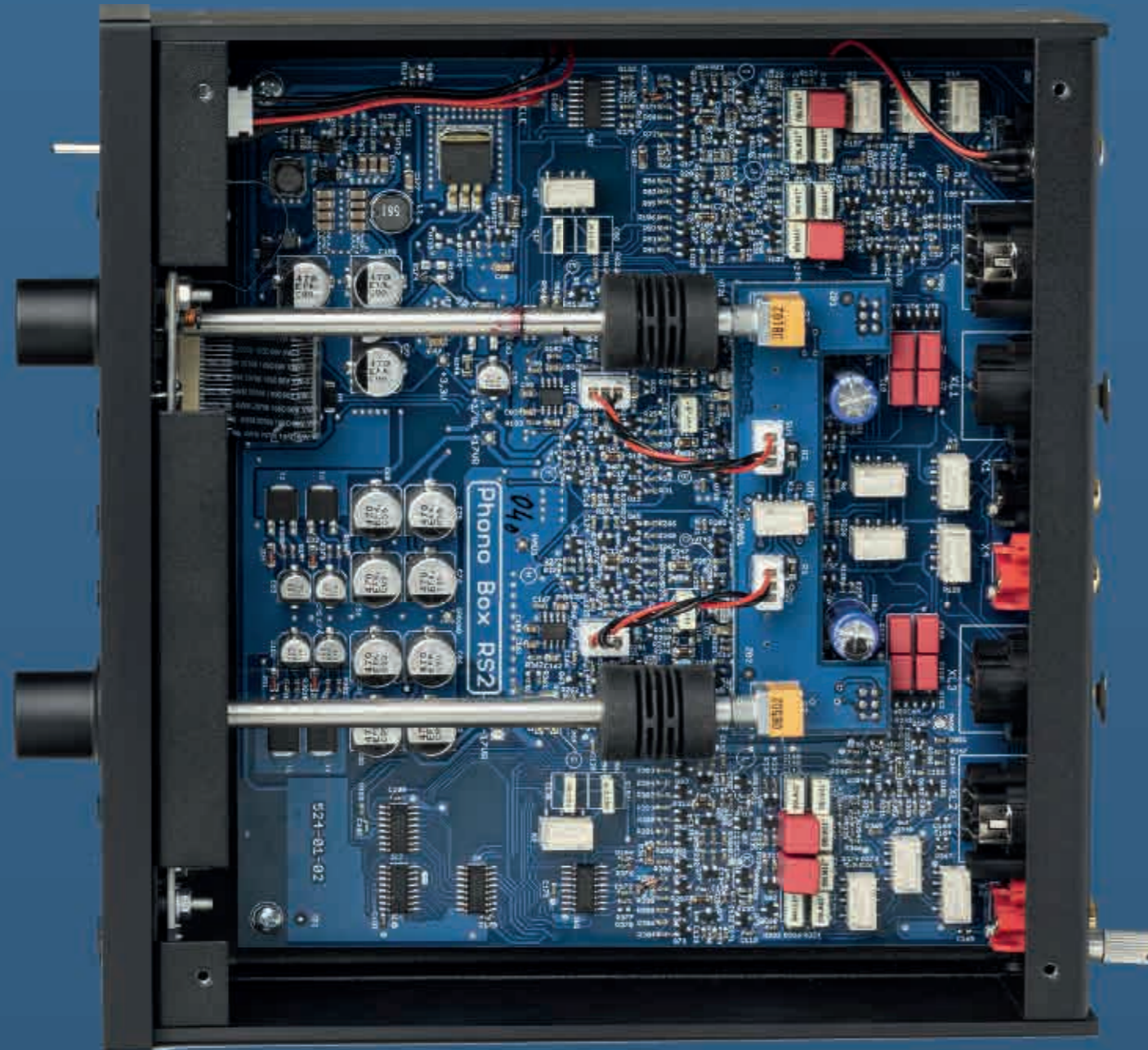

Phono Box RS2



- Fully balanced, fully discrete phono preamp of the highest class • MM & MC capable • Fully balanced, true dual mono design • Fully discrete hardware design - NO Op-amps! • Fully passive RIAA & DECCA equalisation • Balanced XLR & unbalanced RCA In & Outputs • Unique continuously variable input impedance loading and channel balance control to match every cartridge to 100% (adjustment even while playing) • Superior low noise / low distortion • Metal casing protects against vibration and interference • Available in silver or black

● ● 1.599 €

Phono Box RS



- MM & MC capable • True dual mono design • Balanced XLR & unbalanced RCA In & Outputs • Fully passive RIAA & DECCA equalisation • Unique continuously variable input impedance loading, matches every cartridge (adjustment even while playing) • RCA & XLR In & Out • Superior low noise / low distortion • Classy & elegant dip switches • DC power supply (< 1 watt standby power) • Metal casing protects against vibration and interference • Dimensions (with sockets): 206x72x210 mm (WxHxD) • Weight: 2000 g without power supply • Available in silver or black

● ● 999 €

Power Box RS Amp



- Suitable for Pro-Ject Audio Systems power amplifiers • Replaces original "switching" power supplies • Almost double amplifier power output combined with Amp Box RS, Amp Box DS & Stereo Box RS (2x 200/120 watts 4/8 ohms) • Significant sound improvement with better dynamic and bass response, improved soundstage • Compatible with Amp Box RS, Amp Box RS Mono, Stereo Box RS but also with Amp Box DS or Amp Box DS Mono • Big toroidal transformer with copper shielding • Very low output impedance • Filtration capability 40.000 uF capacitors low ESR types • Dimensions: 201x72x195 mm (WxHxD) • Weight: 4800 g • Available in silver or black

● ● 699 €

Power Box RS2 Phono



- All in one power supply for your phono setup • Powers any Pro-Ject 15V DC turntable • Powers any Pro-Ject phono stage • Cleanest power using non-switching power supply • Soft start system avoids current inrush • Audio type toroidal transformer • Main isolating transformer with copper foil shielding • Secondary voltage rectification with precise regulation • High filtration capacity (10.000 µF) • Low ESR capacitors • Low noise components with surge protection • Available in silver or black

● ● 899 €

Power Box RS2 Sources



- Purest & cleanest power using non-switching power supply
- Soft start system avoids current inrush in primary winding
- Audio type toroidal transformer
- Main isolating transformer with copper foil shielding
- Secondary voltage rectification with precise regulation
- High filtration capacity (10.000 µF for each output)
- Low ESR capacitors
- Low noise components with surge protection
- Available in silver or black

● ● 999 €

Power Box RS Uni TT



- Specially developed for turntables with heavy platters (RPM, Xtension & Signature Line)
- Purest & cleanest power using non-switching power supply
- Soft start system avoids current inrush in primary winding
- Audio type toroidal transformer
- Main isolating transformer with copper foil shielding
- Secondary voltage rectification with precise regulation
- High filtration capacity (10.000 µF)
- Low ESR capacitors
- Low noise components with surge protection
- Available in silver or black

● ● 549 €

Control it RS



REMOTE CONTROL

- Control all of your DS/DS2 and RS/RS2 Box Design components with just one remote control.
- Version 2023 - reworked mechanics
- Replaces standard Box Design IR remotes
- more functions (e.g. Tube, Reclocking, etc.)
- extended range (up to 7m)
- Pre-programmed system remote
- Housing metal front made of brushed Aluminium
- Dimension: 200 x 50 x 8 mm
- Weight: 160g

● 279 €



SPEAKERS

Speaker Box 3E Carbon



Stereo Box S3 BT





Speaker Box 3E



• Ultra compact speaker • 2-way bass reflex principle • Small size with big sound
 • Low coloration and great transparency • Frequency response 55Hz - 20kHz •
 Gold-plated speaker terminal • Non-resonating MDF cabinet • Perfect for your
 home cinema & desktop use • Dimensions: 160 x 106 x 152 mm (HxWxD) •
 Weight: 1,37 kg each • Colour options: High gloss white, black, red and walnut

- ● 199 €
- 229 €

Speaker Box 3E Carbon



• Compact audiophile speaker • 2-way bass reflex principle • Audiophile flat fre-
 quency response • Cutting edge fiber glass carbon composite woofer • Highly
 detailed sound stage • Non-resonating MDF cabinet • Magnetic speaker grills
 included • Ideal desktop and home cinema speaker • Dimenson: 175 x 119 x 152
 mm (HxWxD) • Weight: 1,69 kg each • Available in satin black, white and walnut

- ● 299 €
- 349 €



Speaker Box 5



- Audiophile bass-reflex design • Recommended amplifier power 10 to 150 watts • Magnetically shielded • Front cover with magnetic attachment
- Frequency response 55Hz - 20kHz • Gold-plated speaker terminal (single-wired) • Simple Wall-mount included • Speaker-Box Wall Bracket available as an option • Dimensions: 160x255x210 mm (WxHxD) • Weight: 4.2 kg • Colour options: High gloss white, black, red and walnut

○ ● ● ● 279 €

Speaker Box 10



- Audiophile 2-way design • Rear-ported bass-reflex cabinet • Recommended amplifier power 10 to 150 watts • 1" Silk dome tweeter • 2 x 4.5" paper cone midrange/woofers • Magnetic front grilles • Frequency range 50Hz - 20kHz
- Single-wired speaker terminal • Comes with adjustable spikes
- Dimension: 140x920x190 mm (WxHxD) • Weight: 11.7 kg, net each
- Colour options: High gloss white, black and red

● 599 €

Sub Box 50 E



- Audiophile subwoofer • Full sound for any room • Compact size • Perfect companion for Speaker Box 5 and 10 • Low and high level input • Three amplifier modes • Down-firing bass driver • Metal back plate • Ultra stiff non resonating MDF cabinet Dimensions: 205x280x205 mm (WxHxD) • Weight: 6.0 kg • Colour options: High gloss white, black and red

○ ● ● 299 €



Speaker Box 5 S2



- Audiophile bass-reflex design • Sophisticated internal bracing • Ultra stiff non resonating MDF cabinet • Audiophile direct-wired crossover - no PCB • Lead free solder • Ecofriendly glue from Kleiberit • Acoustically transparent front cover with magnetic attachment • Gold-plated speaker terminal (single-wired) • Handmade in Europe • Dimensions: 160x271x215 mm (WxHxD) • Weight: 4.9 kg
- Colour options: Satin White, Satin Black, Walnut, Eucalyptus, Satin Fir Green, Satin Steel Blue, Satin Golden Yellow, Wine Red



Speaker Box 10 S2



- Audiophile 2.5-way design • Rear-ported bass-reflex cabinet • Sophisticated internal bracing • Ultra stiff non resonating MDF cabinet • Audiophile direct-wired crossover - no PCB • Lead free solder • Ecofriendly glue from Kleiberit
- Acoustically transparent front cover with magnetic attachment • Gold-plated speaker terminal (single-wired) • Handmade in Europe • Dimensions: 140x898x195 mm (WxHxD) • Weight: 12.7 kg, net each • Colour options: High gloss black and white and real wood finishes: walnut, eucalyptus



Speaker Box 5 DS2



- Audiophile bass-reflex design • Sophisticated internal bracing • Ultra stiff non resonating MDF cabinet • Audiophile direct-wired crossover - no PCB • Lead free solder • Ecofriendly glue from Kleiberit • Acoustically transparent front cover with magnetic attachment • Gold-plated speaker terminal (single-wired)
- Handmade in Europe • Dimensions: 160x271x215 mm (WxHxD) • Weight: 5.0 kg • Colour options: High gloss black and white and real wood finishes: walnut, eucalyptus



Speaker Box 10 DS2



- Audiophile 2-way design • Rear-ported bass-reflex cabinet • Sophisticated internal bracing • Ultra stiff non resonating MDF cabinet • Audiophile direct-wired crossover - no PCB • Lead free solder • Ecofriendly glue from Kleiberit
- Acoustically transparent front cover with magnetic attachment • Gold-plated speaker terminal (single-wired) • Handmade in Europe • Dimensions: 160x898x195 mm (WxHxD) • Weight: 12.8 kg, net each • Colour options: High gloss black and white and real wood finishes: walnut, eucalyptus



Speaker Box 15 DS2



- Audiophile 2.5-way design • Rear port bass reflex cabinet • Sophisticated internal bracing • Ultra stiff non resonating MDF cabinet • Gravity mass-point by sand filled cabinet • Audiophile direct-wired crossover - no PCB • Lead free solder
- Ecofriendly glue from Kleiberit • Acoustically transparent front cover with magnetic attachment (front and back) • Gold-plated speaker terminal (single-wired)
- Height-adjustable spike feet with supports • Handmade in Europe • Dimensions: 160x978x260 mm (WxHxD) • Weight: 20.6 kg, per piece • Colour options: High gloss black and white and real wood finishes: walnut, eucalyptus

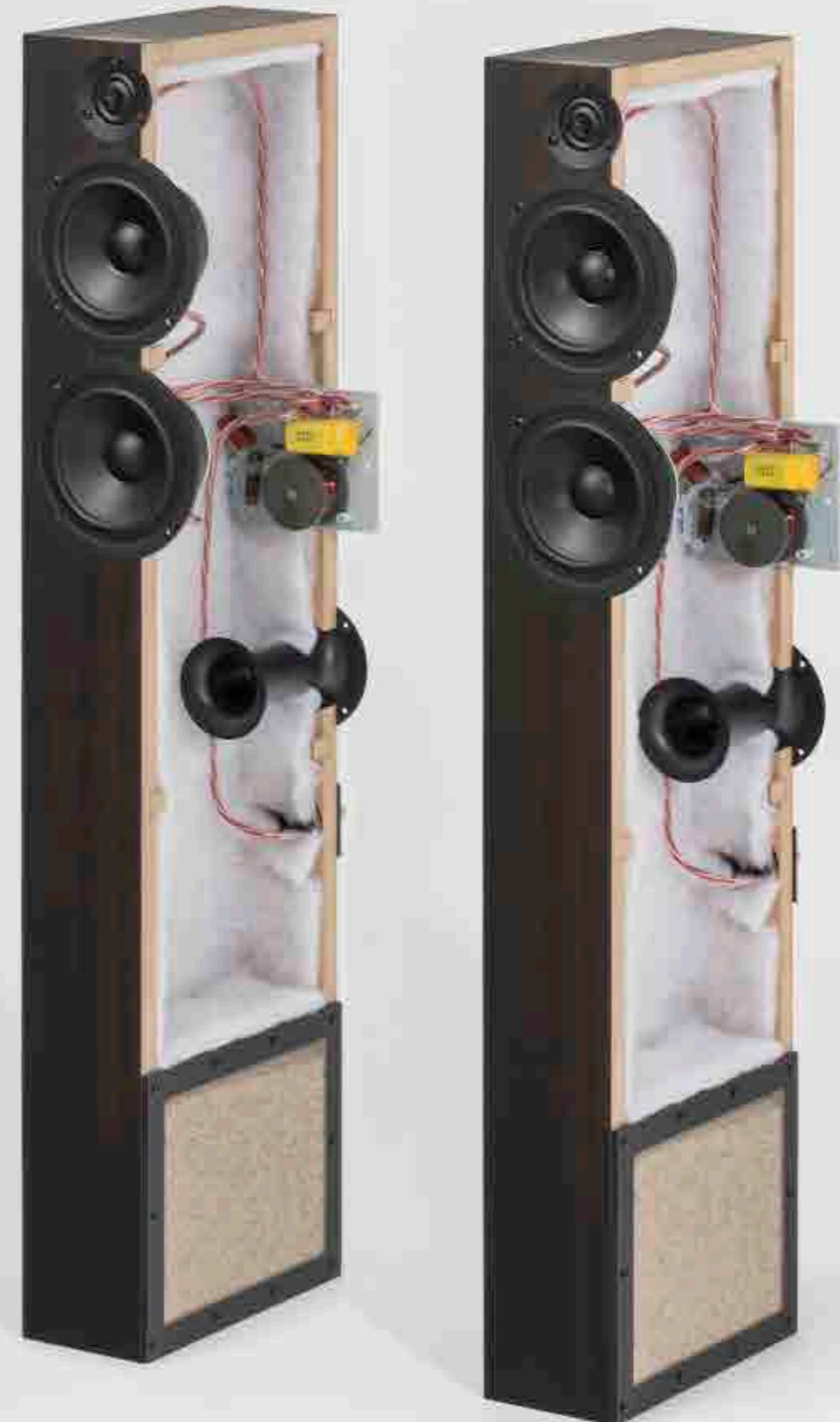

ACCESSORIES



Acrylic Platters



Acryl it is made from acrylic with satinised surface and brings a more liquid sound that leaves no space for platter resonances. Acryl it is able to improve overall performance significantly!

Model	Suitable for	Price
Acryl it E	Elemental, Essential III, Primary E, Juke Box E	129 €
Acryl it	T1, T2, E1, Juke Box E1, Debut Line, 1Xpression	129 €
Acryl it RPM 1 Carbon	RPM 1 Carbon	249 €
Acryl it RPM 3 Carbon	RPM 3 Carbon	299 €



Aluminium Sub Platters



The diamond cut aluminium sub-platter can be machined to much improved and lower tolerances and will be a substantial upgrade to regular sub-platters. It adds more mass to the entire platter and drive system, resulting in additional damping of noise and unwanted resonances. The improved tolerances during production will increase overall speed accuracy.

Model	Price
Debut Alu Sub Platter	149 €
The Classic EVO Alu Sub Platter	149 €
X1/X2 Alu Sub Platter	149 €



Ground it



- Vibration protection gives undisturbed music experience
- Support platform for many turntables or other equipment
- Prevents the transmission of vibrations

Model	Dimensions	Weight	Price
Ground it E	500 x 65 (45) x 400 mm incl spikes (without spikes)	4 kg	159 €
Ground it deluxe 1	500 x 65 (45)x 400 mm incl spikes (without spikes)	11,6 kg	449 €
Ground it deluxe 2	435 x 65 (45)x 340 mm incl. spikes (without spikes)	8,5 kg	399 €
Ground it deluxe 3	500 x 65 (45) x 400 mm incl. feet (without feet)	13,5 kg	799 €
Ground it Carbon	500 x 65 (45) x 400 mm incl spikes (without spikes)	14,5 kg	1.299 €



Record Weights

Record pucks use weight to secure a record against the turntable. This improves the sound performance of the turntable in terms of timing and sound depth.

Model	Weight	Colour	Material	Price
Record Puck E	190gr	Silver or Black	Aluminium	29,90 €
Record Puck PRO	190gr	Nickel plated	Aluminium	49,90 €
Record Puck S	320gr	Silver polished or Black	Aluminium	79 €
Record Puck DS	970gr	Silver polished or Black	Steel	129 €
Record Puck RS	1000gr	Chrome or Black	Brass	149 €
Record Puck Classic	800gr	Raw Brass or Black	Brass	89 €
Glass Record Weight	280gr	Transparent	Glass	49 €



Record Puck PRO



Record Puck E



Record Puck E



Record Puck S



Record Puck S



Record Puck DS



Record Puck DS



Record Puck RS



Record Puck RS



Record Puck



Record Puck



Glass Record Puck
(The Dark Side of the Moon)

Adapt it



- Adaptor for use with 7-inch single records • Locates record centrally on turntable • No plastic - precision CNC-machined • Non-magnetic aluminium
- Suitable for all brands and types of record players • Available in silver, black, acryl

Silver: 12,90 €
 Black: 12,90 €
 Acryl: 14,90 €

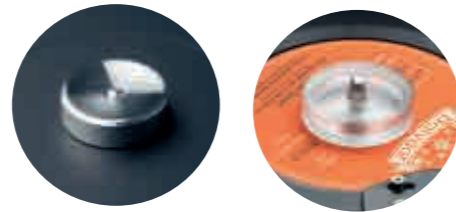

Damp it



- Special absorber feet for effective decoupling • Made from hightech TPE (thermoplastic elastomers) • Prevents transmission of mechanical vibration
- Optimised to absorb frequencies from 20-500 Hz • Especially for bookshelf speakers, Disc players, turntables, tube amplifiers and more • Extremely cost-effective sound upgrade • Available single (bulk) or package containing 4 pieces

4 pieces / 25 €

Headshells



- Fits all tonearms with SME mounting standard • 1/2 inch cartridge mount
- Low resonance construction • Non magnetic • Azimuth adjustment with screw on side • Built-in fingerlift

Model	Price
Headshell S	69 €
Headshell PRO Black	79 €
Headshell PRO Carbon	99 €
Signature Headshells	99-169 €
Signature Headshell Premium Polished	199 €



Slip Mats

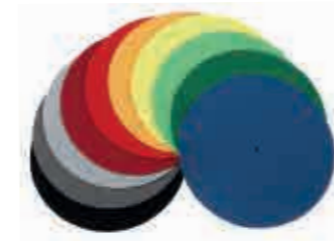

Soundtuning with turntable mat! Every material has its own character. Experiment and descide what you prefer!

Model & material	Price
Felt Mat in different colours	9,90 €
Cork it	25 €
Cork & Rubber it 1mm	49,90 €
Cork & Rubber it 3mm	65 €
Leather it	49 €



Clamp it



- Sound improvement for all turntables • Reduces unwanted resonances while playback • Fast and easy mounting • Fine-adjustment of thightening force
- Full metal accessory with leather coating • Diamond cut finish

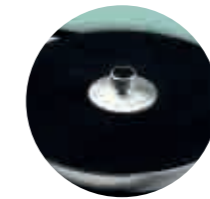

99 €

High Power it



- Proper grounding dramatically reduces grounding hum of „floating mass“ systems/amplifiers • 3 pin DC power supply with ground connection • Delivers cleaner current and more power to all Pro-Ject turntables • Input: 100-240V AC, 1.0A, 50-60Hz • Output: +15V DC, 2.0A • Output power: 30W max. • Diameter DC plug: 2.1mm • Dimensions: 85 x 47 x 33 mm • Weight: 180 g (w/o power cord)

34,90 €

Cloth it



The perfect cleaning tool to polish your turntable and HiFi electronics. Made of microfibre material, purpose selected for the correct and non-abrasive cleaning of the satin and high-gloss finishes of our turntables.

12,90 €

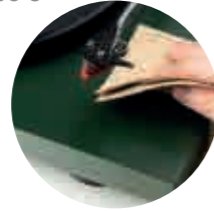

Clean it



- Smooth cleaner for diamant stylus • Conductive carbon fibers
- Eliminates static charges • Removes finest dust particles

9,99 €

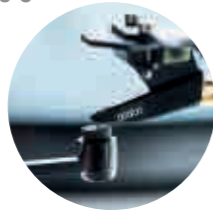

Grease it



- To be used with inverted bearings • Helps a smooth movement
- Pre-filled syringe • Easy handling

17,90 €



Lube it



- High-tech lubricant for constant velocity

22,90 €



Adjust it



- Suitable for all Pro-Ject tonearms • Allows fine adjustment of bearings, if misadjusted • Caution: for qualified personnel only • Includes 2 inserts for different bearings • Full metal (aluminium & brass)

29 €

Align it S

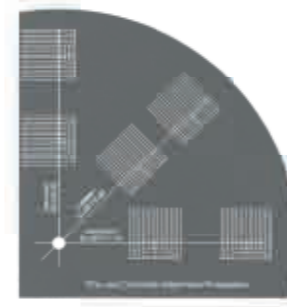

- Multiple protractors on one template • Tool for cartridge alignment and adjustment • Suitable for other manufacturer's tonearms • Suitable for tonearms between 8" and 12" effective arm-length

39,90 €

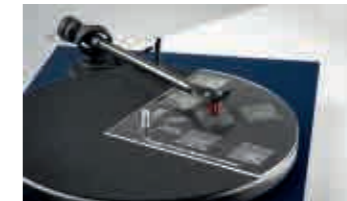

Align it DS3



- Suitable for all Pro-Ject turntables • All adjustments on one tool: Overhang, azimuth and tangentiality • 3 different geometries: Baerwald, Löfgren B, Stevenson • Alignment curves for 8,6", 9", 10" and 12" tonearm • Detailed alignment instructions and guidance on how to choose the geometry that suits your listening habits most!

79 €

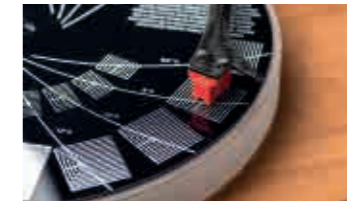

Align it PRO

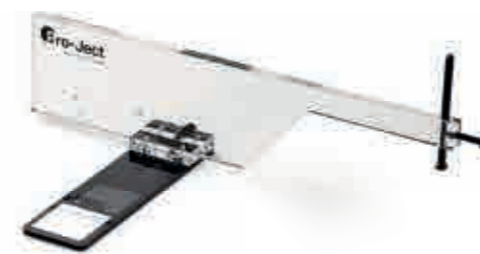

- Suitable for all Pro-Ject turntables • High-precision alignment setup
- Super fast workflow • All adjustments on one tool: Overhang, azimuth and tangentiality • Baerwald geometry • Alignment for 8,6", 9", 10" and 12" tonearms
- Detailed alignment instructions and tonearm geometry explanation included

149 €



Level it



- Spirit level for optimum positioning of a turntable

34,90 €

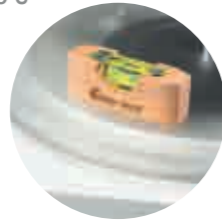

Strobe it



- Control of turntable speed

29 €

Mount it



- Anti-magnetic precision screws • Stable installment of a cartridge • Made of stainless steel • Perfectly stable mounting of a cartridge • Three different sizes • Including allen key

15,90 €



Measure it E



- 4 digit LCD display with backlight • 4 weighing modes • Wide capacity 0 - 5g
- Calibration weight • Precision data readouts with low variance • Auto calibration function • Auto power off after 30 seconds • Low power consumption
- Button cell batteries included

24,90 €



Measure it S2



- Electronic stylus balance • 4 digit LCD-Display with backlight • Capacity 0 – 5g
- Variance $\pm 0,001g$ • Auto calibration function • Auto off after 120 seconds
- Replacement batteries supplied

109 €



Measure it DS



- Capacity 0.01 - 200g • Precision 0,01g • Pre-calibrated at factory for ultimate precision • Scale design optimized to work with any cartridge and tonearm combination • Non-magnetic scale surface especially important for MC cartridges
- Auto off after 60 seconds • 2x AAA batteries included • LCD screen with back lighting

49,90 €



Q up



- Automatic tonearm lifter for manual turntables • Lifts tonearm, when it moves to the end of a record • Extends stylus life • Suits nearly all tonearms and manual turntables • Adjustable trigger sensitivity • No AC or battery power needed • Easy to mount, no additional tools necessary

59 €

VTA it



- With the Pro-Ject VTA it, the vertical tracking angle of the tonearm can be adjusted. You can then use upgrade platters, mats and cartridges. VTA it is compatible with Debut I-III, Debut Carbon, Debut Carbon EVO, Essential I-III (only in the standard configurations). A Philips # 1 screwdriver & 5.5 mm nut driver wrench are required for installation.

19,90 €



Difficulty ■■■■ Expert

Installation Time **20 min**

Brush it



- Carbon-fibre brush for record cleaning

14.99 €



Brush it Premium



- Metal brush with grounding cable • Conductive carbon fibers • Metal handle

24.99 €

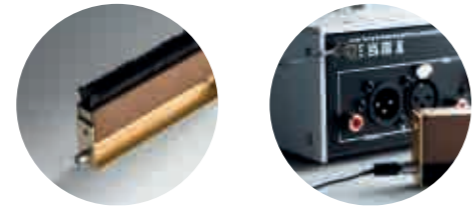

Sweep it E



- Record broom • Gently cleans your vinyl while playing • Heavy weight stand for secure standing • Uni-pivot design • Brush made of natural hair

99 €

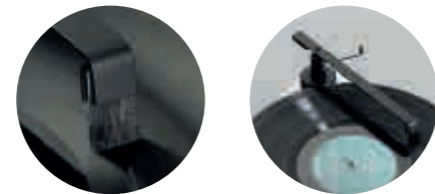

Sweep it S2



- Premium Record broom • Gently cleans your vinyl while playing • Heavy weight stand for secure standing • Neodymium magnet stabilization • Uni-pivot design • Brush made of natural hair • Height adjustable

129 €

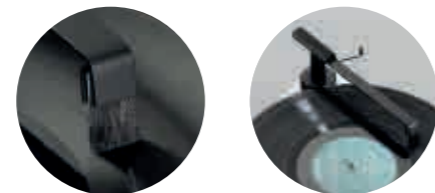

VC-S 7" Kit



- Optimized cleaning efficiency for 7" records • 2 different versions suitable for alu & synthetic flange assembly versions of VC • Vacuum arm for 7" records including short adhesive velvet strips • Clamp for 7" records (standard clamp will not fit) • Wash it vinyl cleaning concentrate (100ml bottle)

119 €

VC-E2



- Improved cabinet design • magnetic clamp for quicker cleaning • improved vacuum steam outlet • self-adhesive arm strip for better cleaning • 5 mm aluminium composite panels • Superfast & superstrong cleaning • Removes cleaning fluid (Wash it) residue free • 0,5l tank for vacuumed cleaning liquid • Completely dry record within 2 rotations • Eco friendly, non-alcoholic, premixed new cleaning fluid Wash it 2 • Removes static load of vinyl records • Clamp seals record label from cleaning fluid

450 €

VC-S3



- Improved cabinet design • magnetic clamp for quick cleaning • silent mode operation • motor speed regulation • 1300W vacuum with power regulation • self-adhesive arm strip for better cleaning • 5 mm aluminium composite panels • Superfast & superstrong cleaning • Superior motor for long lifetime • Big 2,5l tank for vacuumed cleaning liquid • Completely dry record within 2 rotations • Removes static load of vinyl records • Removes cleaning fluid (Wash it) residue free • Eco friendly, non-alcoholic, premixed new cleaning fluid Wash it 2 • High-end build-quality

699 €

Spin-Clean



- Record Washer System • Clean records sound better and help to protect the stylus from dust • Spin Clean is suitable for all kinds of records: LP's, 45's, 78's

Spin Clean Record Washer System MKII:

- Washer basin and lid
- Washer fluid 4oz
- One pair brushes MKII
- One pair rollers MKII
- Two washable drying cloths

99 €

Spin Clean Record Washer System MKII Package LE:

- Translucent washer basin and lid
- Washer fluid 4oz
- Washer fluid 32oz
- Two pair brushes MKII
- One pair rollers MKII
- Seven washable drying cloths

199 €

Wash it 2



- Ready to use • Wash it cleans vinyl records & shellacs • Wash it contains only high-purity components • Eco-friendly - Non-toxic - Non-flammable • Dissolves a wide range of impurities including fat/grease • For very dirty records repeat the cleaning process • Evaporates quickly and leaves zero residues • Optimum application temperature 20 - 40 degrees • Optimum storage temperature 10 - 25 degrees

250 ml 7,90 €
 500 ml 10,90 €
 1000 ml 15,90 €

Accessorie Sets



24,99 €



34,99 €



99 €



89 €



109 €



119 €



149 €



79 €



169 €



399 €



Hear it One Anniversary



- Smart, audiophile & comfortable
- Classic design
- Adjustable leather-coated headband
- Soft leather ear cushions (memory foam)
- Textile coated cable made from oxygen-free copper (HP-OFC)
- Gold plated 3.5mm jack plug
- High gloss & metal finish

99 €

Hear it Two



- Super loud – super light – super cool (107 dB)
- Lightweight design (77 g)
- adjustable ear-cushion position
- flat transport possible
- high wear comfort
- 3.5 mm jack plug
- 3 colour options: red, white, black

○ ● ● 59,90 €



Dustcovers



- Clear acrylic dustcover for turntables:

Model	Dimensions	Price
Cover it E	471 x 103 x 331 mm	99 €
Cover it RPM 1/3	436 x 133 x 386 mm	99 €
Cover it RPM 5/9	498 x 179 x 348 mm	169 €
Cover it 1	525 x 290 x 425 mm	279 €
Cover it 2.1	460 x 250 x 365 mm	279 €
Dustcover Metallica	480 x 480 x 135 mm	199 €





WMI RACK 5/4



Wall mount equipment rack

Size
530 x 1000 x 406 mm

Space between wall and shelf for cables
50 mm

Weight
12.6 kg

Maximum weight load per shelf
50 kg

Shelf Surface
498 x 355 mm

Adaptor plate (Pair of 2 pcs): 99 €

Maximum height between shelves
167 mm

Colour Options ● ○ Black or White: 599 €

Wallmount it



• Resonance-free wall mount for turntables & Hifi • WMI wall mounts use rigid steel frame construction • Height-adjustable spikes to level the board

Model	Dimensions	Colors	Max Load	Price
Wallmount it 1	460 x 355mm	black	30kg	229 €
Wallmount it 2	460 x 355mm	black & white	30kg	249 €
Wallmount it 3	520 x 450mm	black	30kg	449 €
Wallmount it 5	460 x 400mm	black & walnut	30kg	329 €



Wallmount it 1



Wallmount it 2



Wallmount it 3



Wallmount it 5

Tristand



• Premium rigid steel speaker stand • Clean design with intelligent features
• Reissue of a Pro-Ject classic • Solid steel frame construction

Colour Options ● ○ Black or White: 399 €

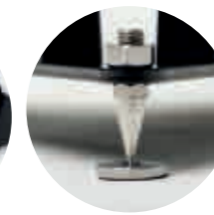

24 EVO TONEARMS



An Evolutionary Tonearm Range

Our new EVO tonearm ranges employ two different quality level bearing blocks, two shapes, three lengths and two finishes. That gives you a total of 24 different arms to choose from. Pro-Ject has been designing tonearms for more than three decades. We have tested many arms in listening and measuring sessions with close to 50 cartridges of different types and technology.

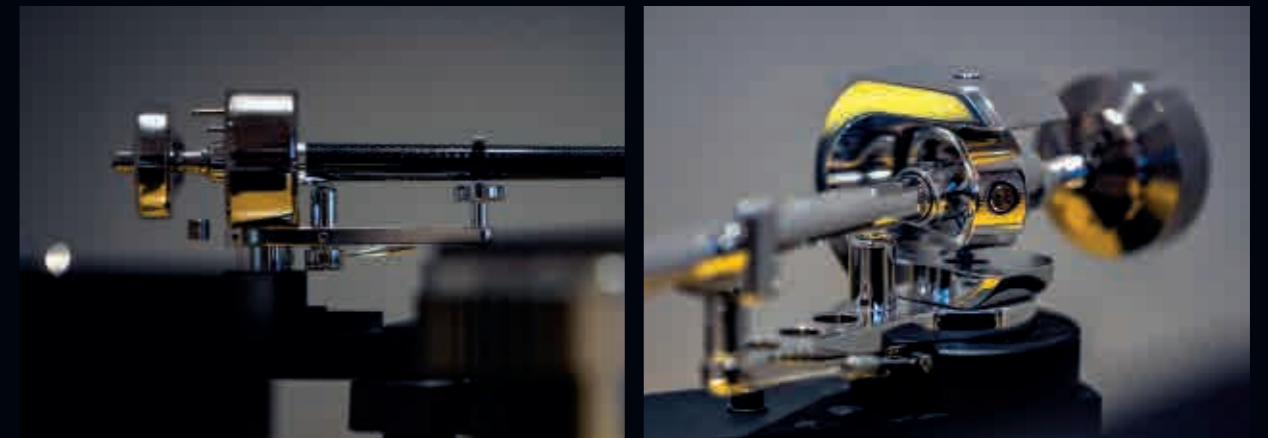
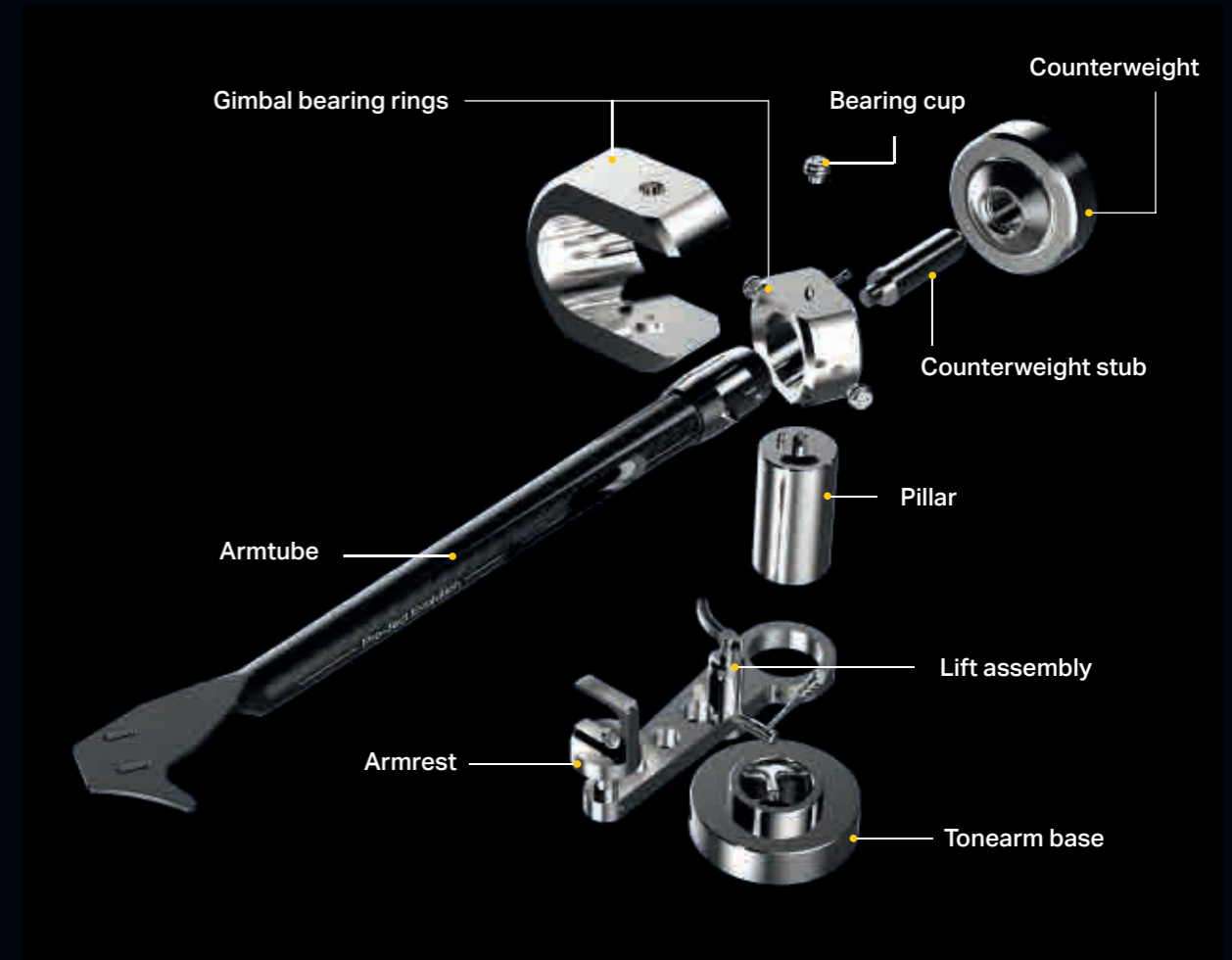

STRAIGHT
EVO CC BLACK

Satin Black Finish



Lenght	Type	Finish	Tube
9, 10 or 12"	STRAIGHT	BLACK	CARBON



TONEARM EVO 9 CC BLACK | EAN: 9120007688528 | € 799,00
 TONEARM EVO 10 CC BLACK | EAN: 9120007688580 | € 850,00
 TONEARM EVO 12 CC BLACK | EAN: 9120007688641 | € 899,00

S-SHAPE
EVO CA PREMIUM BLACK

Satin Black Finish



Lenght	Type	Finish	Tube Design
9, 10 or 12"	STRAIGHT	BLACK	ALU. / CARBON
Bearing	Cables	Materials	Counterweight
NEW DESIGN	SILVER WIRES	STAINL. STEEL	NEW DESIGN



TONEARM EVO 9 CA PREMIUM BLACK | EAN: 9120007688528 | € 1.399,00
 TONEARM EVO 10 CA PREMIUM BLACK | EAN: 9120122295519 | € 1.450,00
 TONEARM EVO 12 CA PREMIUM BLACK | EAN: 9120122295557 | € 1.499,00

S-SHAPE
EVO CC HG

Silver Finish
Polished by hand

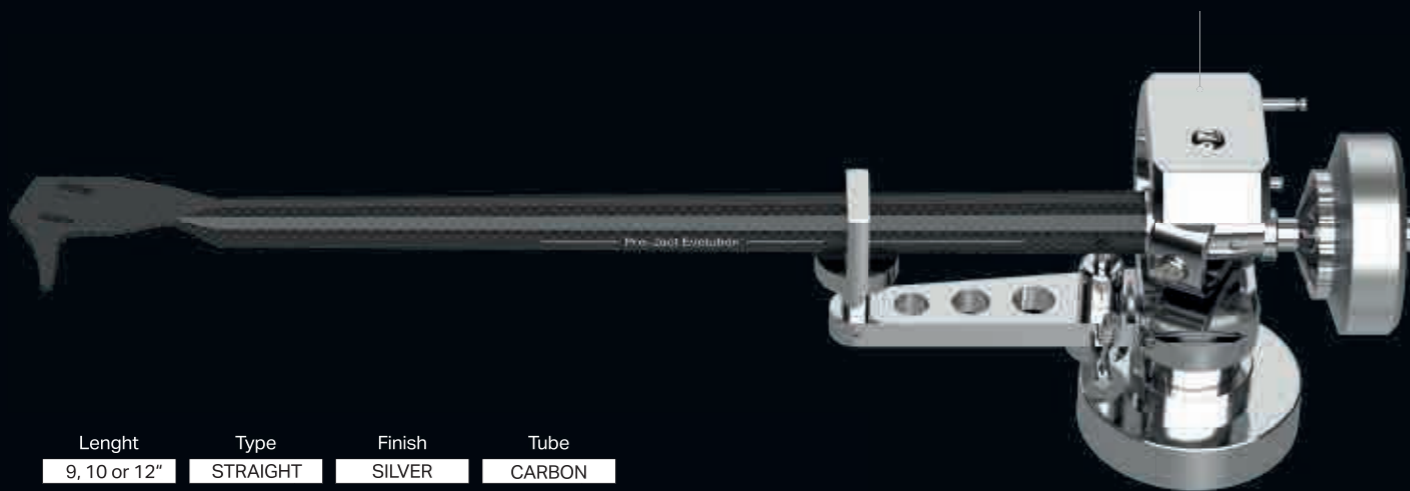

Lenght	Type	Finish	Tube
9, 10 or 12"	STRAIGHT	SILVER	CARBON



TONEARM EVO 9 CC HG | EAN: 9120122295380 | € 1.299,00
 TONEARM EVO 10 CC HG | EAN: 9120122295410 | € 1.350,00
 TONEARM EVO 12 CC HG | EAN: 9120122295441 | € 1.399,00

S-SHAPE
EVO CA PREMIUM HG

Silver Finish
Polished by hand

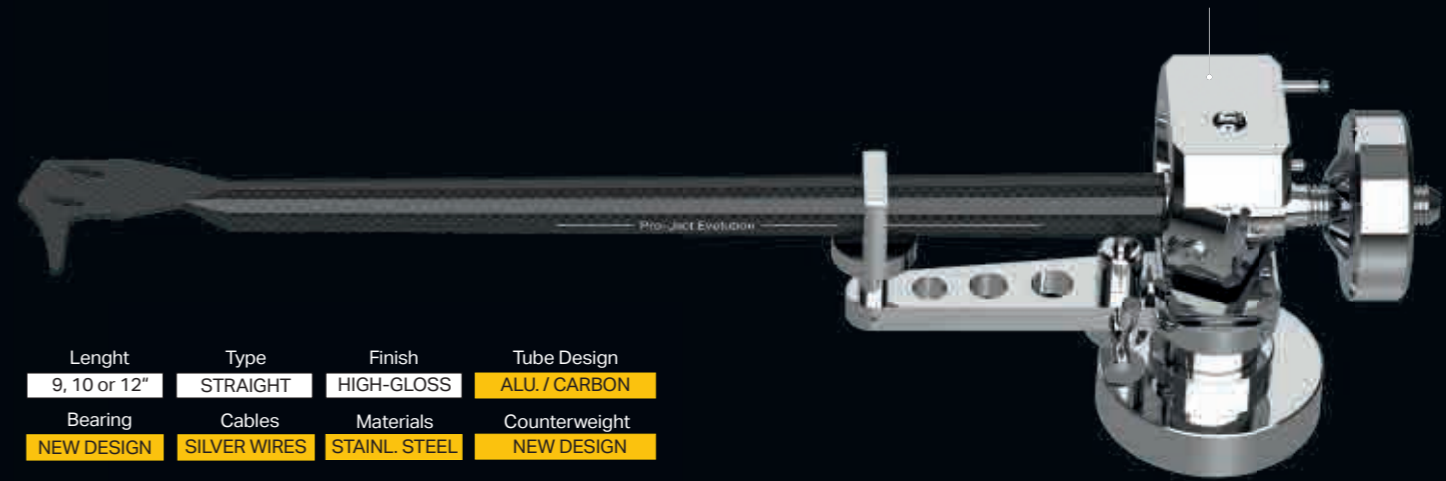

Lenght	Type	Finish	Tube Design
9, 10 or 12"	STRAIGHT	HIGH-GLOSS	ALU. / CARBON
Bearing	Cables	Materials	Counterweight
NEW DESIGN	SILVER WIRES	STAINL. STEEL	NEW DESIGN

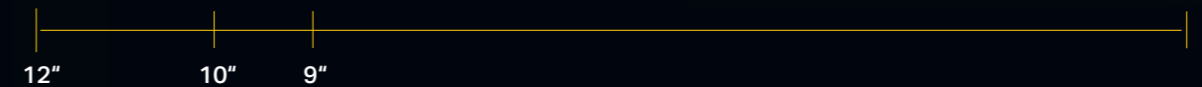

TONEARM EVO 9 CA PREMIUM HG | EAN: 9120122295489 | € 1.899,00
 TONEARM EVO 10 CA PREMIUM HG | EAN: 9120122295526 | € 1.950,00
 TONEARM EVO 12 CA PREMIUM HG | EAN: 9120122295564 | € 1.999,00

S-SHAPE

EVO AS BLACK

Satin Black Finish



Lenght	Type	Finish	Tube
9, 10 or 12"	S-SHAPE	BLACK	ALUMINIUM



TONEARM EVO 9 AS BLACK | EAN: 9120122295403 | € 1.099,00
 TONEARM EVO 10 AS BLACK | EAN: 9120122295434 | € 1.150,00
 TONEARM EVO 12 AS BLACK | EAN: 9120122295465 | € 1.199,00

S-SHAPE

EVO AS PREMIUM BLACK

Satin Black Finish



Lenght	Type	Finish	Tube Design
9, 10 or 12"	S-SHAPE	BLACK	ALUMINIUM
Bearing	Cables	Materials	Counterweight
NEW DESIGN	SILVER WIRES	STAINL. STEEL	NEW DESIGN



TONEARM EVO 9 AS PREMIUM BLACK | EAN: 9120122295502 | € 1.699,00
 TONEARM EVO 10 AS PREMIUM BLACK | EAN: 9120122295540 | € 1.750,00
 TONEARM EVO 12 AS PREMIUM BLACK | EAN: 9120122295588 | € 1.799,00

S-SHAPE

EVO AS HG

Silver Finish
Polished by hand



Lenght	Type	Finish	Tube
9, 10 or 12"	S-SHAPE	HIGH-GLOSS	ALUMINIUM



TONEARM EVO 9 AS HG | EAN: 9120122295397 | € 1.699,00
 TONEARM EVO 10 AS HG | EAN: 9120122295427 | € 1.750,00
 TONEARM EVO 12 AS HG | EAN: 9120122295458 | € 1.799,00

S-SHAPE

EVO AS PREMIUM HG

Silver Finish
Polished by hand



Lenght	Type	Finish	Tube Design
9, 10 or 12"	S-SHAPE	HIGH-GLOSS	ALUMINIUM
Bearing	Cables	Materials	Counterweight
NEW DESIGN	SILVER WIRES	STAINL. STEEL	NEW DESIGN



TONEARM EVO 9 AS PREMIUM HG | EAN: 9120122295496 | € 2.299,00
 TONEARM EVO 10 AS PREMIUM HG | EAN: 9120122295533 | € 2.350,00
 TONEARM EVO 12 AS PREMIUM HG | EAN: 9120122295571 | € 2.399,00

SIGNATURE TONEARMS

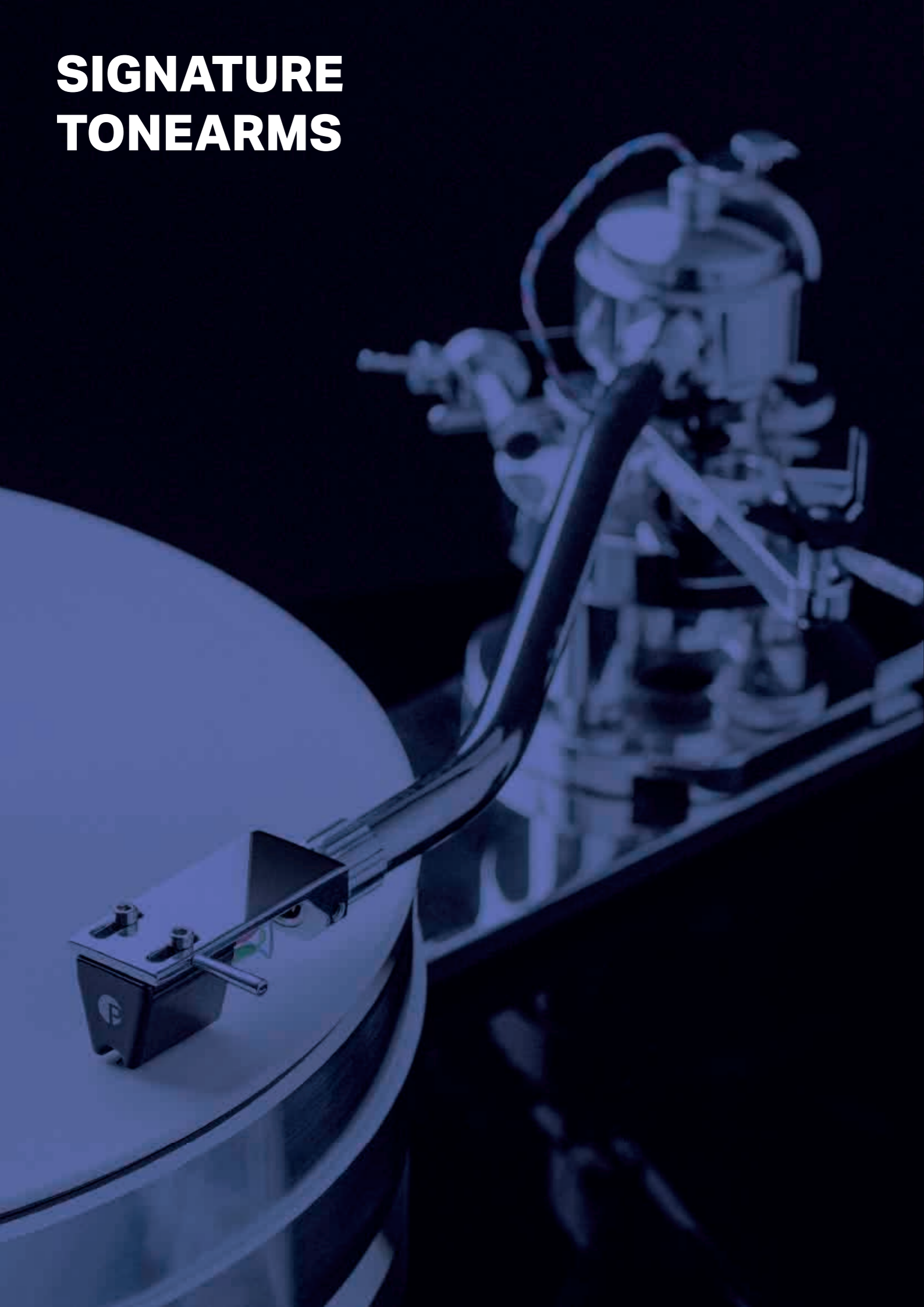

S-SHAPE

Signature Tonearms

Lenght	Type	Finish	Tube
9, 10 or 12"	S-SHAPE	SILVER	ALU

TONEARM SIGNATURE 9" | EAN: 9120050438149 | € 2.199,00
 TONEARM SIGNATURE 10" | EAN: 9120050438156 | € 2.299,00
 TONEARM SIGNATURE 12" | EAN: 9120050438163 | € 2.499,00

MC 1



• Moving Coil principle • Spherical on alu cantilever • Output voltage = 0.4 mV at 3.54 cm/s • Frequency response = 20-20kHz (+/- 1dB) • Cartridge weight = 5 g • Recommended tracking force = 1.9 g • Silver grey colour • Designed in EU

299 €

MC 2



• Moving Coil principle • Elliptical on alu cantilever • Output voltage = 0.3 mV at 3.54 cm/s • Frequency response = 20-20kHz (+/- 1dB) • Cartridge weight = 5 g • Recommended tracking force = 1.9 g • Golden yellow colour • Designed in EU

399 €

MC 3



• Moving Coil principle • Pro-Ject specific „Hyper-Spherical“ • Output voltage at 1 kHz = 0,4 mV (3,54 cm/sec) • Frequency response = 20-20kHz (+/- 1dB) • Recommended tracking force = 2g • Cartridge weight = 9.6g • ARMCO pure iron cross coil • Cryogenic treated cantilever • 1/2 inch mounting standard • Full aluminium body • Steel Blue colour • Dimensions, without connection pins and stylus (W x H x D) = 17x12.5x21mm • Designed & assembled in EU

599 €

MC 9



• Moving Coil principle • Pro-Ject specific „Special-Elliptical“ • Output voltage at 1 kHz = 0,35 mV (3,54 cm/sec) • Flat frequency response • Frequency response = 20-20kHz (+/- 1dB) • Recommended tracking force = 1.8g • Cartridge weight = 9.6g • Full aluminium body • Telar 57 coil • Cryogenic treated cantilever • 1/2 inch mounting standard • Black colour • Dimensions, without connection pins and stylus (W x H x D) = 17x12.5x21mm • Designed & assembled in EU

1.399 €

Lead it C



Headshell cable made from high-purity copper • Upgrade for your SME headshell • Spring connector technology • Easy installation - perfect contact • High purity 99,999% OFC copper leads • 7 x 0,1mm core strand construction • Gold plated beryllium copper connectors • Colour coded cables

15 €

Lead it Premium Silver



Headshell cable made from high-purity silver • High end upgrade for your SME headshell • Spring connector technology • Easy installation - perfect contact • High-purity silver conductors • 7 x 0,08 mm core strand construction • Gold plated beryllium copper connectors • Colour coded cable

29 €

Pin it



• Headshell Connector Pins • includes 8 pieces • Perfect fit • easy installation • Beryllium Copper • Perfect connection • Spring contact technology

9.90 €

Headshell Spacer Carbon



These headshell spacers made out of carbon fibre allow you to precisely adjust the height of your cartridge. Especially usefull, as this might spare you from needing lower the VTA of your tonearm when changing cartridges. Using these spacers can also improve headshell resonances.

Set includes 4 thicknesses: 1,5 / 2 / 2,5 / 3 mm

59 €

Pick it PRO Balanced



• Moving Magnet principle • Stylus type = Elliptical • True Balanced compatible MM cartridge • Very detailed with low distortion • Simple and fast mounting • 1/2 inch mounting standard • Threaded holes for simple mounting without nuts • As with most MM cartridges, stylus can be exchanged • Made in Europe

249 €

Pick it PRO



• Moving Magnet principle • Stylus type = Elliptical • Very detailed with low distortion • Simple and fast mounting • 1/2 inch mounting standard • Threaded holes for simple mounting without nuts • As with most MM cartridges, stylus can be exchanged • Made in Europe

199 €

Pick it S2 MM



• Moving Magnet principle • Split pole pins enables frequency responses that compares very well to MC cartridges • Suitable for low to medium tonearm masses • 1/2 inch mounting standard • High trackability • Pick it S2 MM should be connected to phono MM inputs • As with most MM cartridges, stylus may be exchanged • Made in Europe

119 €

Pick it S2 C



• Moving Magnet principle • Simple and fast setup • High output voltage Ideal for medium weight tonearms (15-20g) • Very dynamic • Suitable for MM phono stages • Needle can be exchanged if needed • Robust Polycarbonate body • As with most MM cartridges, stylus may be exchanged • Made in Europe

129 €

Pick it 2M Silver



• Moving Magnet principle • Coil windings made from pure silver to achieve higher quality and more dynamic playback compared with conventional MM cartridges • Suitable for low to medium tonearm masses • 1/2 inch mounting standard • High trackability • 2M Silver should be connected to phono MM inputs • As with most MM cartridges, stylus may be exchanged

199 €

Pick it 25A



• Moving Magnet principle • Coil windings made from pure silver to achieve higher quality and more dynamic playback compared with conventional MM cartridges • Suitable for low to medium tonearm masses • 1/2 inch mounting standard • High trackability • Pick it 25A should be connected to phono MM inputs • As with most MM cartridges, stylus can be exchanged

69 €

Pick it Mono



• Moving Magnet principle • Mono Phono Cartridge • The perfect partner for mono records • Suitable for low to medium tonearm masses • 1/2 inch mounting standard • High trackability • Pick it Mono should be connected to phono MM inputs

99 €

Pick it MM EVO



• Moving Magnet principle • Stylus type = Elliptical • Very detailed with low distortion • Simple and fast mounting • 1/2 inch mounting standard • Threaded holes for simple mounting without nuts • As with most MM cartridges, stylus can be exchanged • Made in Europe

149 €

Why quality cables are important?

Cables are not able to make your sound system sound better, but they ensure that **every detail** and information **of the signal** is transmitted to the dedicated receiving device. Using a poor cable can limit your whole HiFi setup and definitely can be the bottleneck of your sound experience.

Our new Connect it cable lineup **covers all your needs** and not only offers different connection types & technologies, but also various conductor & plug materials. It perfectly matches each quality levels of our products.

With our **experience of 30 years** in HiFi we developed four cable lines which cover all your needs for analogue audio systems.



High quality materials

Metal plugs & highest purity conductors



Connector diversity

XLR, mini XLR, 5P DIN and more



Made with care

Technically correct & beautiful optics



More infos: www.project-audio.com/connect-it-cables

Comparison Chart - Speaker Cables

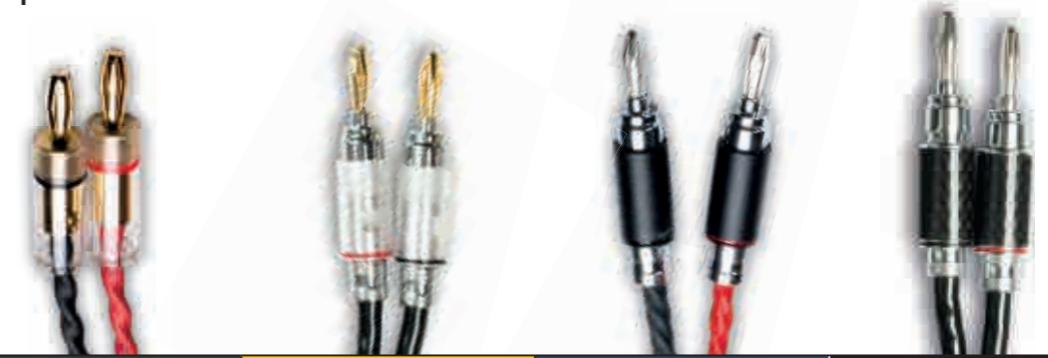

	E Line	S Line	DS RCA	RS RCA
Geometry	Solid core twisted circular array			
Conductor	99,9% OFC oxygen free copper	99,9% OFC oxygen free copper	99,9% OFC oxygen free copper	99,999% OCC continuous cast copper
Construction	4 x 0,75 mm ² solid core	4 x 0,75 mm ² solid core	8 x 0,75 mm ² solid core	4 x 0,75 mm ² solid core
Dielectric	High density Polyethylene			
Jacket	Transparent PVC	PVC covered with black mesh	PVC covered with black with white stripes mesh	PVC covered with metallic dark grey mesh
Connector	Ø 4mm banana - spades available on request			
	Gold plated brass	Gold plated phosphor-bronze	Silver plated copper	Rhodium plated berillium copper

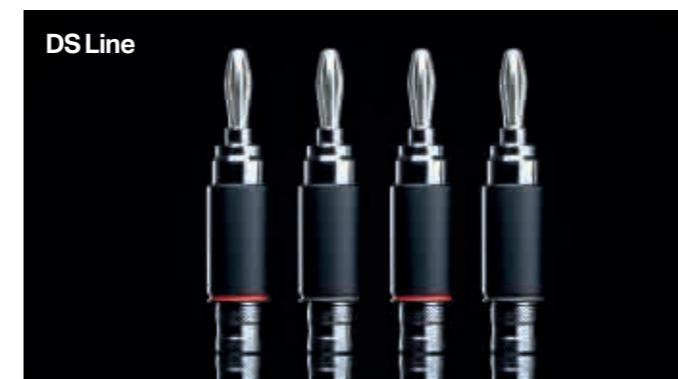

E

High Performance signal cables, optimized for use with turntables and other audio components. These highly flexible and perfectly shielded cables offer low capacitance without any coloration in sound. „**State-of-the-Art**“ components for leads, dielectrics and plugs were chosen after intense listening tests.

1	Line E RCA	0,41m / 0,82m / 1,23m	MSRP 29,90€ - 49,90€	EAN: 9120129861502
2	Phono E RCA	1,23m	MSRP 59,90€	EAN: 9120122294093
3	Phono E 5P/RCA	1,23m	MSRP 69,90€	EAN: 9120122294130
4	Phono E RCA / mini XLR (f)	1,23m	MSRP 69,90€	EAN: 9120122293836
5	Phono E mini XLR (f) / mini XLR (m)	1,23m	MSRP 69,90€	EAN: 9120122293829
6	LS E	3m / 4m	MSRP 79,90€ / 89,90	EAN: 9120082388528

Line Cables	Connectors	Available Lengths
Line E RCA	RCA <-> RCA	0,41 / 0,82 / 1,23 m

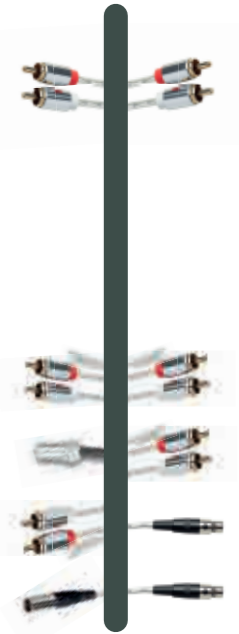

Phono Cables	Connectors	Available Lengths
Phono E RCA	RCA <-> RCA + Ground wire	1,23 m
Phono E 5P / RCA	5P DIN <-> RCA + Ground wire	
Phono E RCA / mini XLR	RCA <-> mini XLR female + Ground wire	
Phono E mini XLR / mini XLR	mini XLR male <-> mini XLR female	

S

The Connect it **S** cables feature a shielded flexible OFC copper conductor for an interference free signal transmission. The gold plated connectors ensure a low contact resistance for a lifetime. Connect it S cables are handmade with care in Europe.



1	Line S RCA	0,205 / 0,41 / 0,82 / 1,23 / 1,85m	MSRP 79,90€ - 109,90€	EAN (0,41m): 9120122293942
2	Phono S RCA	1,23m	MSRP 119,90€	EAN: 9120122294109
3	Phono S 5P / mini XLR (f)	1,23m	MSRP 129,00€	EAN: 9120129863070
4	Phono S RCA / mini XLR (f)	1,23m	MSRP 129,00€	EAN: 9120129863094
5	Phono S mini XLR (f) / mini XLR (m)	1,23m	MSRP 129,00€	EAN: 9120129863087
6	LS S	3,0 / 4,0m	MSRP 199,00€ / 219,00€	EAN (3m): 9120122294215

Line Cables	Connector Types	Available Lengths
Line S RCA	RCA <-> RCA	0,205 / 0,41 / 0,82 / 1,23 / 1,85 m

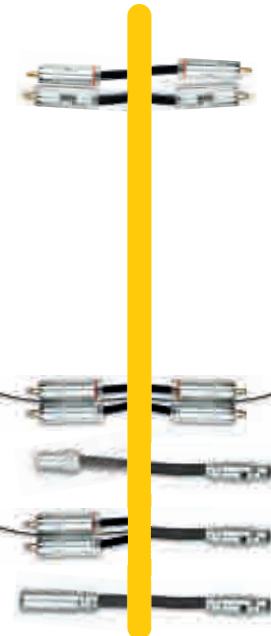

Phono Cables	Connector Types	Available Lengths
Phono S RCA	RCA <-> RCA + Ground wire	1,23 m
Phono S 5P / mini XLR	5P DIN <-> mini XLR female	
Phono E RCA / mini XLR	RCA <-> mini XLR female + Ground wire	
Phono S mini XLR / mini XLR	mini XLR male <-> mini XLR female	

DS

The Connect it **DS** cables feature OFC copper signal lines combined with silver plated full metal connectors. This combination results in a neutral, high quality signal transmission. The different connector types offer a broad compatibility with many products and transmission types.



1	Line DS RCA	0,41 / 0,82 / 1,23 / 1,85m	MSRP 139,00€ - 199,00€	EAN (1,23): 9120122293980
2	Line DS XLR	0,41 / 0,82 / 1,23 / 1,85m	MSRP 159,00€ - 219,00€	EAN (1,23): 9120122294048
3	Phono DS RCA	1,23m	MSRP 189,00€	EAN: 9120122294116
4	Phono DS 5P / RCA	1,23m	MSRP 199,00€	EAN: 9120122294147
5	Phono DS 5P / XLR	1,23m	MSRP 219,00€	EAN: 9120129863117
6	Phono DS 5P / mini XLR (f)	1,23m	MSRP 199,00€	EAN: 9120129863100
7	Phono DS RCA / mini XLR (f)	1,23m	MSRP 199,00€	EAN: 9120122293621
8	Phono DS mini XLR (m) / mini XLR (f)	1,23m	MSRP 199,00€	EAN: 9120122293652
9	Phono DS mini XLR (m) / XLR (m)	1,23m	MSRP 219,00€	EAN: 9120122293638
10	LS DS	3,0 / 4,0m	MSRP 299,00€ - 329,00€	EAN (3m): 9120122294246

Line Cables	Connector Types	Available Lengths
Line DS RCA	RCA <-> RCA	0,41 / 0,82 / 1,23 / 1,85 m
Line DS XLR	XLR female <-> XLR male	0,41 / 0,82 / 1,23 / 1,85 m



Phono Cables	Connector Types	Available Lengths
Phono DS RCA	RCA <-> RCA + Ground wire	1,23 m
Phono DS 5P / RCA	5P DIN <-> RCA + Ground wire	
Phono DS 5P / XLR	5P DIN <-> XLR male	
Phono DS 5P / mini XLR	5P DIN <-> mini XLR female	
Phono DS RCA / mini XLR	RCA <-> mini XLR female	
Phono DS mini XLR / mini XLR	mini XLR male <-> mini XLR female	
Phono DS mini XLR / XLR	mini XLR male <-> XLR male	

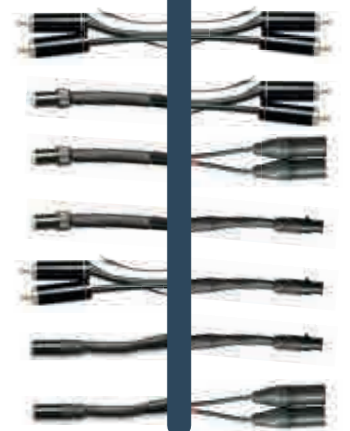

RS

The Connect it **RS** line represents our top-notch cables. The signal lines are made out of highest-grade silver strands which results in a lower resistivity and better conductivity compared to copper. The low capacitance reduces high-frequency attenuation and ensures perfect transmission over the entire frequency range.



1	Line RS RCA	0,41 / 0,82 / 1,23 / 1,85m	MSRP 499,00€ - 799,00€	EAN (1,23): 9120122294017
2	Line RS XLR	0,41 / 0,82 / 1,23 / 1,85m	MSRP 550,00€ - 850,00€	EAN (1,23): 9120122294079
3	Phono RS RCA	1,23m	MSRP 699,00€	EAN: 9120122294123
4	Phono RS 5P / RCA	1,23m	MSRP 750,00€	EAN: 9120122294154
5	Phono RS 5P / XLR	1,23m	MSRP 799,00€	EAN: 9120122294178
6	LS RS	3,0 / 4,0m	MSRP 699,00€ / 799,00€	EAN (3m): 9120122296226

Line Cables	Connector Types	Available Lengths
Line RS RCA	RCA <-> RCA	0,41 / 0,82 / 1,23 / 1,85 m
Line RS XLR	XLR female <-> XLR male	0,41 / 0,82 / 1,23 / 1,85 m



Phono Cables	Connector Types	Available Lengths
Phono RS RCA	RCA <-> RCA + Ground wire	1,23 m
Phono DS 5P / RCA	5P DIN <-> RCA + Ground wire	
Phono DS 5P / XLR	5P DIN <-> XLR male	



Beethoven's
„Pastoral“ & „Egmont“
39,90 €



Richard Strauss
„Also sprach Zarathustra“
39,90 €



Gustav Mahler
Symphony No2
39,90 €



7RAY feat. Triple Ace
Jazzy Zoetrope
39,90 €



W. A. Mozart
No. 25, 35 & 39
39,90 €



Ginga
Yes / No
22,99 €



DELADAP
ReJazzed
35 €



Hans Theessink
„70 Birthday Bash“
39,90 €



Hans Theessink
„Slow Train“
25,99 €



Mistysa
Macumba
15,90 €



Hans Theessink
Hard Road Blues
49,90 €



Arik Brauer
Von Haus zu Haus
39,90 €



Vinyl Essentials
Test Record
39,90 €



www.project-audio.com/lps

Merch for...



Polo Shirt
"Pro-Ject Logo"
€ 25,00



T-Shirt
"HiFi Stereo"
€ 26,00



Scent it
Soap
25,00 €



Lanyard
€ 2,50



Linen Bag
„HiFi-Stereo“
€ 7,90



Scent it
Candle
€ 29,00



some other fun.





Pro-Ject Audio Systems
a Division of Audio Tuning Vertriebs GmbH

Margaretenstraße 98
1050, Vienna, AUSTRIA

Headquarter & Logistics:
Wirtschaftspark A5 Mistelbach/Wilfersdorf
Analogweg 1, 2130 Mistelbach, AUSTRIA

E-Mail: info@project-audio.com
Heinz Lichtenegger (CEO)

www.project-audio.com
[instagram.com/projectaudiosystems](https://www.instagram.com/projectaudiosystems)
www.facebook.com/PJ.Audio.Systems

Lifestyle photography location Debut Carbon EVO:
Hotel Altstadt Vienna.
Technical data and prices without engagement.
Printed in Austria by Riedel druck.



